

4101:8-3-01 Building planning.

[Comment: When a reference is made within this rule to a federal statutory provision, an industry consensus standard, or any other technical publication, the specific date and title of the publication as well as the name and address of the promulgating agency are listed in rule 4101:8-44-01 of the Administrative Code. The application of the referenced standards shall be limited and as prescribed in section 102.5 of rule 4101:8-1-01 of the Administrative Code.]

SECTION 301
DESIGN CRITERIA

301.1 Application. Buildings and structures, and parts thereof, shall be constructed to safely support all loads, including dead loads, live loads, roof loads, flood loads, snow loads, wind loads and seismic loads as prescribed by this code. The construction of buildings and structures in accordance with the provisions of this code shall result in a system that provides a complete load path that meets the requirements for the transfer of loads from their point of origin through the load-resisting elements to the foundation. Buildings and structures constructed as prescribed by this code are deemed to comply with the requirements of this section.

301.1.1 Alternative provisions. As an alternative to the requirements in Section 301.1, the following standards are permitted subject to the limitations of this code and the limitations therein. Where engineered design is used in conjunction with these standards, the design shall comply with the *Ohio building code*.

1. AWC Wood Frame Construction Manual (WFCM).
2. AISI Standard for Cold-Formed Steel Framing - Prescriptive Method for One- and Two-Family Dwellings (AISI S230).
3. ICC Standard on the Design and Construction of Log Structures (ICC 400).

301.1.2 Construction systems. The requirements of this code are based on platform and balloon-frame construction for light-frame buildings. The requirements for concrete and masonry buildings are based on a balloon framing system. Other framing systems must have equivalent detailing to ensure force transfer, continuity and compatible deformations.

301.1.3 Engineered design. Where a building of otherwise conventional construction contains structural elements exceeding the limits of Section 301

or otherwise not conforming to this code, these elements shall be designed in accordance with accepted engineering practice. The extent of such design need only demonstrate compliance of nonconventional elements with other applicable provisions and shall be compatible with the performance of the conventional framed system. Engineered design in accordance with the *Ohio building code* is permitted for buildings and structures, and parts thereof, included in the scope of this code.

301.2 Climatic and geographic design criteria. Buildings shall be constructed in accordance with the provisions of this code as limited by the provisions of this section. Additional criteria shall be established by the local jurisdiction and set forth in Table 301.2(1).

301.2.1 Wind design criteria. Buildings and portions thereof shall be constructed in accordance with the wind provisions of this code using the ultimate design wind speed in Table 301.2(1) as determined from Figure 301.2(5)A. The structural provisions of this code for wind loads are not permitted where wind design is required as specified in Section 301.2.1.1. Where different construction methods and structural materials are used for various portions of a building, the applicable requirements of this section for each portion shall apply. Where not otherwise specified, the wind loads listed in Table 301.2(2) adjusted for height and exposure using Table 301.2(3) shall be used to determine design load performance requirements for wall coverings, curtain walls, roof coverings, exterior windows, skylights, garage doors and exterior doors. Asphalt shingles shall be designed for wind speeds in accordance with Section 905.2.4. A continuous load path shall be provided to transmit the applicable uplift forces in Section 802.11.1 from the roof assembly to the foundation.

301.2.1.1 Wind limitations and wind design required. *Deleted*

301.2.1.1.1 Sunrooms. Sunrooms shall comply with AAMA/NPEA/NSA 2100. For the purpose of applying the criteria of AAMA/NPEA/NSA 2100 based on the intended use, sunrooms shall be identified as one of the following categories by the permit applicant, design professional or the property owner or owner's agent in the construction documents. Component and cladding pressures shall be used for the design of elements that do not qualify as main windforce-resisting systems. Main windforce-resisting system pressures shall be used for the design of elements assigned to provide support and stability for the overall sunroom.

- 1. Category I:** A thermally isolated sunroom with walls that are open or enclosed with insect screening or 0.5 mm (20 mil) maximum thickness plastic film. The space is non-habitable and unconditioned.
- 2. Category II:** A thermally isolated sunroom with enclosed walls. The openings are enclosed with translucent or transparent plastic or glass. The space is non-habitable and unconditioned.
- 3. Category III:** A thermally isolated sunroom with enclosed walls. The openings are enclosed with translucent or transparent plastic or glass. The sunroom fenestration complies with additional requirements for air infiltration resistance and water penetration resistance. The space is non-habitable and unconditioned.
- 4. Category IV:** A thermally isolated sunroom with enclosed walls. The sunroom is designed to be heated or cooled by a separate temperature control or system and is thermally isolated from the primary structure. The sunroom fenestration complies with additional requirements for water penetration resistance, air infiltration resistance and thermal performance. The space is non-habitable and conditioned.
- 5. Category V:** A sunroom with enclosed walls. The sunroom is designed to be heated or cooled and is open to the main structure. The sunroom fenestration complies with additional requirements for water penetration resistance, air infiltration resistance and thermal performance. The space is habitable and conditioned.

301.2.1.2 Protection of openings. Deleted

301.2.1.2.1 Application of ASTM E1996. Deleted

TABLE 301.2.1.2 **WINDBORNE DEBRIS PROTECTION FASTENING SCHEDULE FOR** **WOOD STRUCTURAL PANELS**

Deleted

301.2.1.3 Wind speed conversion. Where referenced documents are based on nominal design wind speeds and do not provide the means for conversion between ultimate design wind speeds and nominal design wind speeds, the ultimate design wind speeds, V_{ult} , of Figure 301.2(5)A shall be

converted to nominal design wind speeds, V_{asd} , using Table 301.2.1.3.

TABLE 301.2.1.3
WIND SPEED CONVERSIONS^a

V_{ult}	110	115	120	130	140	150	160	170	180	190	200
V_{asd}	85	89	93	101	108	116	124	132	139	147	155

For SI: 1 mile per hour = 0.447 m/s.

a. Linear interpolation is permitted.

301.2.1.4 Exposure category. For each wind direction considered, an exposure category that adequately reflects the characteristics of ground surface irregularities shall be determined for the site at which the building or structure is to be constructed. For a site located in the transition zone between categories, the category resulting in the largest wind forces shall apply. Account shall be taken of variations in ground surface roughness that arise from natural topography and vegetation as well as from constructed features. For a site where multiple detached one-, two- and three family dwellings, *Ohio building code group R occupancies permitted to use this code* or other structures are to be constructed as part of a subdivision or master-planned community, or are otherwise designated as a developed area by the authority having jurisdiction, the exposure category for an individual structure shall be based on the site conditions that will exist at the time when all adjacent structures on the site have been constructed, provided that their construction is expected to begin within 1 year of the start of construction for the structure for which the exposure category is determined. For any given wind direction, the exposure in which a specific building or other structure is sited shall be assessed as being one of the following categories:

- 1. Exposure B.** Urban and suburban areas, wooded areas or other terrain with numerous closely spaced obstructions having the size of single-family dwellings or larger. Exposure B shall be assumed unless the site meets the definition of another type exposure.
- 2. Exposure C.** Open terrain with scattered obstructions, including surface undulations or other irregularities, having heights generally less than 30 feet (9144 mm) extending more than 1,500 feet (457 m) from the building site in any quadrant. This exposure shall apply to any building located within Exposure B type terrain where the building is directly adjacent to open areas of Exposure C type terrain in any quadrant for a distance of more than 600 feet (183 m). This category includes flat, open country and grasslands.
- 3. Exposure D.** Flat, unobstructed areas exposed to wind flowing over open water, smooth mud flats, salt flats and unbroken ice for a distance

of not less than 5,000 feet (1524 m). This exposure shall apply only to those buildings and other structures exposed to the wind coming from over the unobstructed area. Exposure D extends downwind from the edge of the unobstructed area a distance of 600 feet (183 m) or 20 times the height of the building or structure, whichever is greater.

**TABLE 301.2(1)
CLIMATIC AND GEOGRAPHIC DESIGN CRITERIA**

GROUND SNOW LOAD ^a	WIND DESIGN Speed ^d (mph)	SEISMIC DESIGN CATEGORY	SUBJECT TO DAMAGE FROM			WINTER DESIGN TEMP. °C	ICE BARRIER UNDERLAYMENT REQUIRED ^h	FLOOD HAZARDS ^g	AIR FREEZING INDEX ⁱ	MEAN ANNUAL TEMP. ^j
			Weathering ^a	Frost line depth ^b	Termite ^c					
	115		severe		Moderate to heavy		Yes			
MANUAL J DESIGN CRITERIAⁿ										
<i>Deleted portion of table – owners shall use manual J when required by this code</i>										

For SI: 1 pound per square foot = 0.0479 kPa, 1 mile per hour = 0.447 m/s.

- a. Where weathering requires a higher strength concrete or grade of masonry than necessary to satisfy the structural requirements of this code, the frost line depth strength required for weathering shall govern. The grade of masonry units shall be determined from ASTM C34, C55, C62, C73, C90, C129, C145, C216 or C652.
- b. Where the frost line depth requires deeper footings than indicated in Figure R403.1(1), the frost line depth strength required for weathering shall govern. The jurisdiction shall fill in the frost line depth column with the minimum depth of footing below finish grade.
- c. Indicates the need for protection depending on whether there has been a history of local subterranean termite damage.
- d. Wind exposure category shall be determined on a site-specific basis in accordance with Section 301.2.1.4.
- e. The outdoor design dry-bulb temperature shall be determined from the following table:

STATION	HEATING DEGREE DAYS (Yearly Total)	DESIGN TEMPERATURES	DEGREES NORTH LATITUDE
Akron-Canton	6,037	6°	41°00' – 40°50'
Cincinnati	4,410	6°	39°10'
Cleveland	6,351	5°	41°30'
Columbus	5,660	5°	40°00'
Dayton	5,622	4°	39°50'
Mansfield	6,403	5°	40°50'
Sandusky	5,796	6°	41°30'
Toledo	6,494	1°	41°40'
Youngstown	6,417	4°	41°10'

Deviations from the tabulated temperatures shall be permitted to reflect local climates or local weather experience as documented by the building official.

- f. The jurisdiction shall fill in this part of the table with the seismic design category determined from Section 301.2.2.1.
- g. The jurisdiction shall fill in this part of the table with (a) the date of the jurisdiction's entry into the National Flood Insurance Program (date of adoption of the first code or ordinance for management of flood hazard areas), (b) the date(s) of the Flood Insurance Study and (c) the panel numbers and dates of the currently effective FIRMs and FBFMs or other flood hazard map adopted by the authority having jurisdiction, as amended.
- h. In accordance with Sections 905.1.2, 905.4.3.1, 905.5.3.1, 905.6.3.1, 905.7.3.1 and 905.8.3.1, all jurisdictions in Ohio have a history of local damage from the effects of ice damming.
- i. The jurisdiction shall fill in this part of the table with the 100-year return period air freezing index (BF-days) from Figure 403.3(2) or from the 100-year (99 percent) value on the National Climatic Data Center data table "Air Freezing Index-USA Method (Base 32°F)."
- j. The jurisdiction shall fill in this part of the table with the mean annual temperature from the National Climatic Data Center data table "Air Freezing Index-USA Method (Base 32°F)."
- k. Topographic wind speed-up effects -Deleted
- l. Unusual wind conditions -Deleted
- m. Wind-borne debris wind zone(s) -Deleted
- n. The jurisdiction shall fill in these sections of the table to establish the design criteria using Table 1a or 1b from ACCA Manual J or established criteria determined by the jurisdiction.
- o. The jurisdiction shall fill in this section of the table using the Ground Snow Loads in Figure 301.2(6).

TABLE 301.2(2)
COMPONENT AND CLADDING LOADS FOR A BUILDING WITH A MEAN ROOF HEIGHT OF
30 FEET LOCATED IN EXPOSURE B (ASD) (psf)^{a, b, c, d, e}

	ZONE	EFFECTIVE WIND AREA (feet ²)	ULTIMATE DESIGN WIND SPEED, V_{ULT} (mph)																	
			110		115		120		130		140		150		160		170		180	
Roof 0 to 7 degrees	1	10	10.0	-13.0	10.0	-14.0	10.0	-15.0	10.0	-18.0	10.0	-21.0	9.9	-24.0	11.2	-27.0	12.6	-31.0	14.2	-35.0
	1	20	10.0	-12.0	10.0	-13.0	10.0	-15.0	10.0	-17.0	10.0	-20.0	9.2	-23.0	10.6	-26.0	11.9	-30.0	13.3	-34.1
	1	50	10.0	-12.0	10.0	-13.0	10.0	-14.0	10.0	-17.0	10.0	-19.0	8.5	-22.0	10.0	-26.0	10.8	-29.0	12.2	-32.9
	1	100	10.0	-11.0	10.0	-13.0	10.0	-14.0	10.0	-16.0	10.0	-19.0	7.8	-22.0	10.0	-25.0	10.0	-28.0	11.3	-32.0
	2	10	10.0	-21.0	10.0	-23.0	10.0	-26.0	10.0	-30.0	10.0	-35.0	9.9	-40.0	11.2	-46.0	12.6	-52.0	14.2	-58.7
	2	20	10.0	-19.0	10.0	-21.0	10.0	-23.0	10.0	-27.0	10.0	-31.0	9.2	-36.0	10.6	-41.0	11.9	-46.0	13.3	-52.4
	2	50	10.0	-16.0	10.0	-18.0	10.0	-19.0	10.0	-23.0	10.0	-26.0	8.5	-30.0	10.0	-34.0	10.8	-39.0	12.2	-44.1
	2	100	10.0	-14.0	10.0	-15.0	10.0	-16.0	10.0	-19.0	10.0	-22.0	7.8	-26.0	10.0	-30.0	10.0	-33.0	11.3	-37.9
	3	10	10.0	-33.0	10.0	-36.0	10.0	-39.0	10.0	-46.0	10.0	-53.0	9.9	-61.0	11.2	-69.0	12.6	-78.0	14.2	-88.3
	3	20	10.0	-27.0	10.0	-29.0	10.0	-32.0	10.0	-38.0	10.0	-44.0	9.2	-50.0	10.6	-57.0	11.9	-65.0	13.3	-73.1
Roof > 7 to 27 degrees	1	10	10.0	-11.0	10.0	-13.0	10.0	-14.0	10.5	-16.0	12.2	-19.0	14.0	-22.0	15.9	-25.0	17.9	-28.0	20.2	-32.0
	1	20	10.0	-11.0	10.0	-12.0	10.0	-13.0	10.0	-16.0	11.1	-18.0	12.8	-21.0	14.5	-24.0	16.4	-27.0	18.4	-31.1
	1	50	10.0	-11.0	10.0	-12.0	10.0	-13.0	10.0	-15.0	10.0	-18.0	11.1	-20.0	12.7	-23.0	14.3	-26.0	16.0	-29.9
	1	100	10.0	-10.0	10.0	-11.0	10.0	-12.0	10.0	-15.0	10.0	-17.0	9.9	-20.0	11.2	-22.0	12.6	-25.0	14.2	-29.0
	2	10	10.0	-20.0	10.0	-22.0	10.0	-24.0	10.5	-29.0	12.2	-33.0	14.0	-38.0	15.9	-44.0	17.9	-49.0	20.2	-55.8
	2	20	10.0	-19.0	10.0	-20.0	10.0	-22.0	10.0	-26.0	11.1	-31.0	12.8	-35.0	14.5	-40.0	16.4	-45.0	18.4	-51.2
	2	50	10.0	-16.0	10.0	-18.0	10.0	-20.0	10.0	-23.0	10.0	-27.0	11.1	-31.0	12.7	-35.0	14.3	-40.0	16.0	-45.4
	2	100	10.0	-15.0	10.0	-16.0	10.0	-18.0	10.0	-21.0	10.0	-24.0	9.9	-28.0	11.2	-32.0	12.6	-36.0	14.2	-40.9
	3	10	10.0	-30.0	10.0	-33.0	10.0	-36.0	10.5	-43.0	12.2	-49.0	14.0	-57.0	15.9	-65.0	17.9	-73.0	20.2	-82.4
	3	20	10.0	-28.0	10.0	-31.0	10.0	-34.0	10.0	-40.0	11.1	-46.0	12.8	-53.0	14.5	-60.0	16.4	-68.0	18.4	-77.0
Roof > 27 to 45 degrees	1	10	11.9	-13.0	13.1	-14.0	14.2	-15.0	16.7	-18.0	19.4	-21.0	22.2	-24.0	25.3	-27.0	28.5	-31.0	32.0	-35.0
	1	20	11.6	-12.0	12.7	-13.0	13.8	-14.0	16.2	-17.0	18.8	-20.0	21.6	-23.0	24.6	-26.0	27.7	-29.0	31.1	-33.2
	1	50	11.2	-11.0	12.2	-12.0	13.3	-13.0	15.6	-16.0	18.1	-18.0	20.8	-21.0	23.6	-24.0	26.7	-27.0	29.9	-30.8
	1	100	10.9	-10.0	11.9	-11.0	12.9	-12.0	15.1	-15.0	17.6	-17.0	20.2	-20.0	22.9	-22.0	25.9	-25.0	29.0	-29.0
	2	10	11.9	-15.0	13.1	-16.0	14.2	-18.0	16.7	-21.0	19.4	-24.0	22.2	-28.0	25.3	-32.0	28.5	-36.0	32.0	-40.9
	2	20	11.6	-14.0	12.7	-16.0	13.8	-17.0	16.2	-20.0	18.8	-23.0	21.6	-27.0	24.6	-30.0	27.7	-34.0	31.1	-39.1
	2	50	11.2	-13.0	12.2	-15.0	13.3	-16.0	15.6	-19.0	18.1	-22.0	20.8	-25.0	23.6	-29.0	26.7	-32.0	29.9	-36.8
	2	100	10.9	-13.0	11.9	-14.0	12.9	-15.0	15.1	-18.0	17.6	-21.0	20.2	-24.0	22.9	-27.0	25.9	-31.0	29.0	-35.0
	3	10	11.9	-15.0	13.1	-16.0	14.2	-18.0	16.7	-21.0	19.4	-24.0	22.2	-28.0	25.3	-32.0	28.5	-36.0	32.0	-40.9
	3	20	11.6	-14.0	12.7	-16.0	13.8	-17.0	16.2	-20.0	18.8	-23.0	21.6	-27.0	24.6	-30.0	27.7	-34.0	31.1	-39.1
Wall	4	10	13.1	-14.0	14.3	-15.0	15.5	-16.0	18.2	-19.0	21.2	-22.0	24.3	-26.0	27.7	-30.0	31.2	-33.0	35.0	-37.9
	4	20	12.5	-13.0	13.6	-14.0	14.8	-16.0	17.4	-19.0	20.2	-22.0	23.2	-25.0	26.4	-28.0	29.7	-32.0	33.4	-36.4
	4	50	11.7	-12.0	12.8	-14.0	13.9	-15.0	16.3	-17.0	19.0	-20.0	21.7	-23.0	24.7	-27.0	27.9	-30.0	31.3	-34.3
	4	100	11.1	-12.0	12.1	-13.0	13.2	-14.0	15.5	-17.0	18.0	-19.0	20.6	-22.0	23.5	-25.0	26.5	-29.0	29.8	-32.7
	4	500	10.0	-10.0	10.6	-11.0	11.6	-12.0	13.6	-15.0	15.8	-17.0	18.1	-20.0	20.6	-22.0	23.2	-25.0	26.1	-29.0
	5	10	13.1	-17.0	14.3	-19.0	15.5	-20.0	18.2	-24.0	21.2	-28.0	24.3	-32.0	27.7	-37.0	31.2	-41.0	35.0	-46.8
	5	20	12.5	-16.0	13.6	-17.0	14.8	-19.0	17.4	-22.0	20.2	-26.0	23.2	-30.0	26.4	-34.0	29.7	-39.0	33.4	-43.7
	5	50	11.7	-14.0	12.8	-16.0	13.9	-17.0	16.3	-20.0	19.0	-23.0	21.7	-27.0	24.7	-31.0	27.9	-35.0	31.3	-39.5
	5	100	11.1	-13.0	12.1	-14.0	13.2	-16.0	15.5	-19.0	18.0	-22.0	20.6	-25.0	23.5	-28.0	26.5	-32.0	29.8	-36.4
	5	500	10.0	-10.0	10.6	-11.0	11.6	-12.0	13.6	-15.0	15.8	-17.0	18.1	-20.0	20.6	-22.0	23.2	-25.0	26.1	-29.0

For SI: 1 foot = 304.8 mm, 1 square foot = 0.0929 m², 1 mile per hour = 0.447 m/s, 1 pound per square foot = 0.0479 kPa.

- a. The effective wind area shall be equal to the span length multiplied by an effective width. This width shall be permitted to be not less than one-third the span length. For cladding fasteners, the effective wind area shall not be greater than the area that is tributary to an individual fastener.
- b. For effective areas between those given, the load shall be interpolated or the load associated with the lower effective area shall be used.
- c. Table values shall be adjusted for height and exposure by multiplying by the adjustment coefficient in Table 301.2(3).
- d. See Figure 301.2(8) for location of zones.
- e. Plus and minus signs signify pressures acting toward and away from the building surfaces.

TABLE 301.2(3)
HEIGHT AND EXPOSURE ADJUSTMENT COEFFICIENTS FOR TABLE 301.2(2)

MEAN ROOF HEIGHT	EXPOSURE		
	B	C	D
15	1.00	1.21	1.47
20	1.00	1.29	1.55
25	1.00	1.35	1.61
30	1.00	1.40	1.66
35	1.05	1.45	1.70
40	1.09	1.49	1.74
45	1.12	1.53	1.78
50	1.16	1.56	1.81
55	1.19	1.59	1.84
60	1.22	1.62	1.87

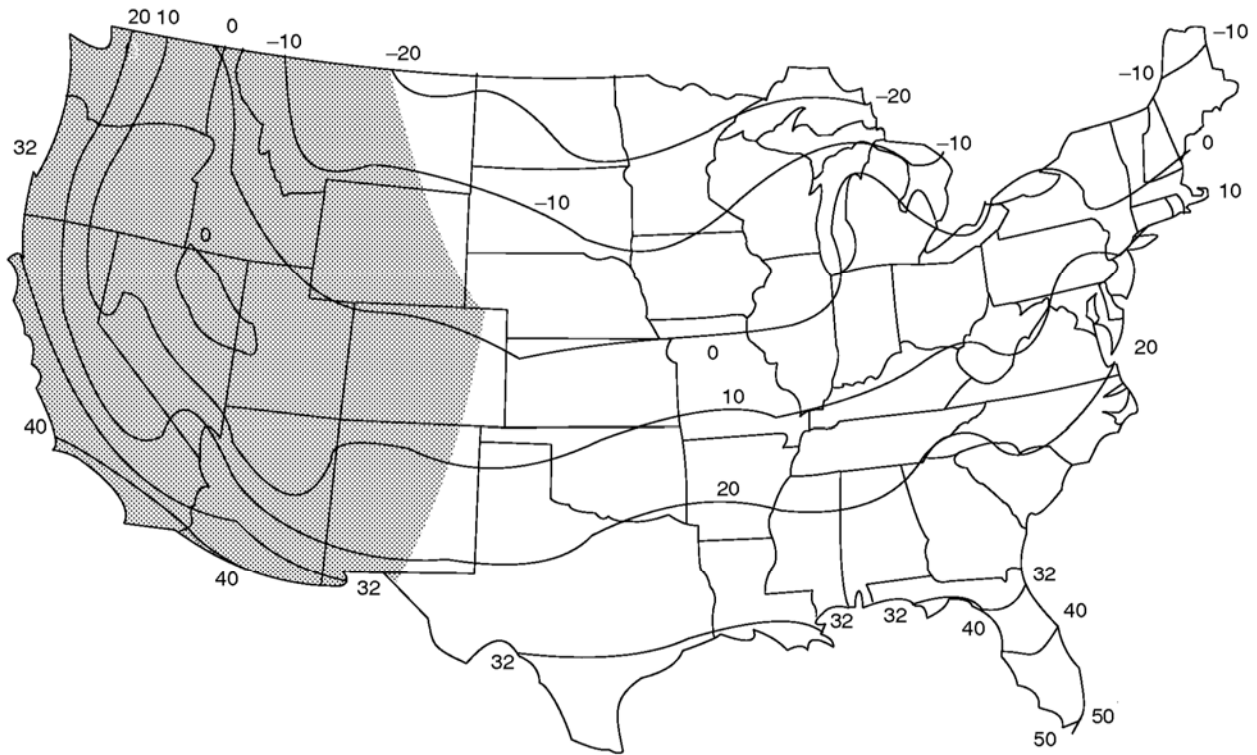

 DESIGN TEMPERATURES IN THIS AREA MUST BE BASED ON ANALYSIS OF LOCAL CLIMATE AND TOPOGRAPHY

For SI: °C = [(°F)-32]/1.8.

FIGURE 301.2(1)
ISOLINES OF THE 97¹/₂ -PERCENT WINTER (DECEMBER, JANUARY AND FEBRUARY) DESIGN TEMPERATURES (°F)

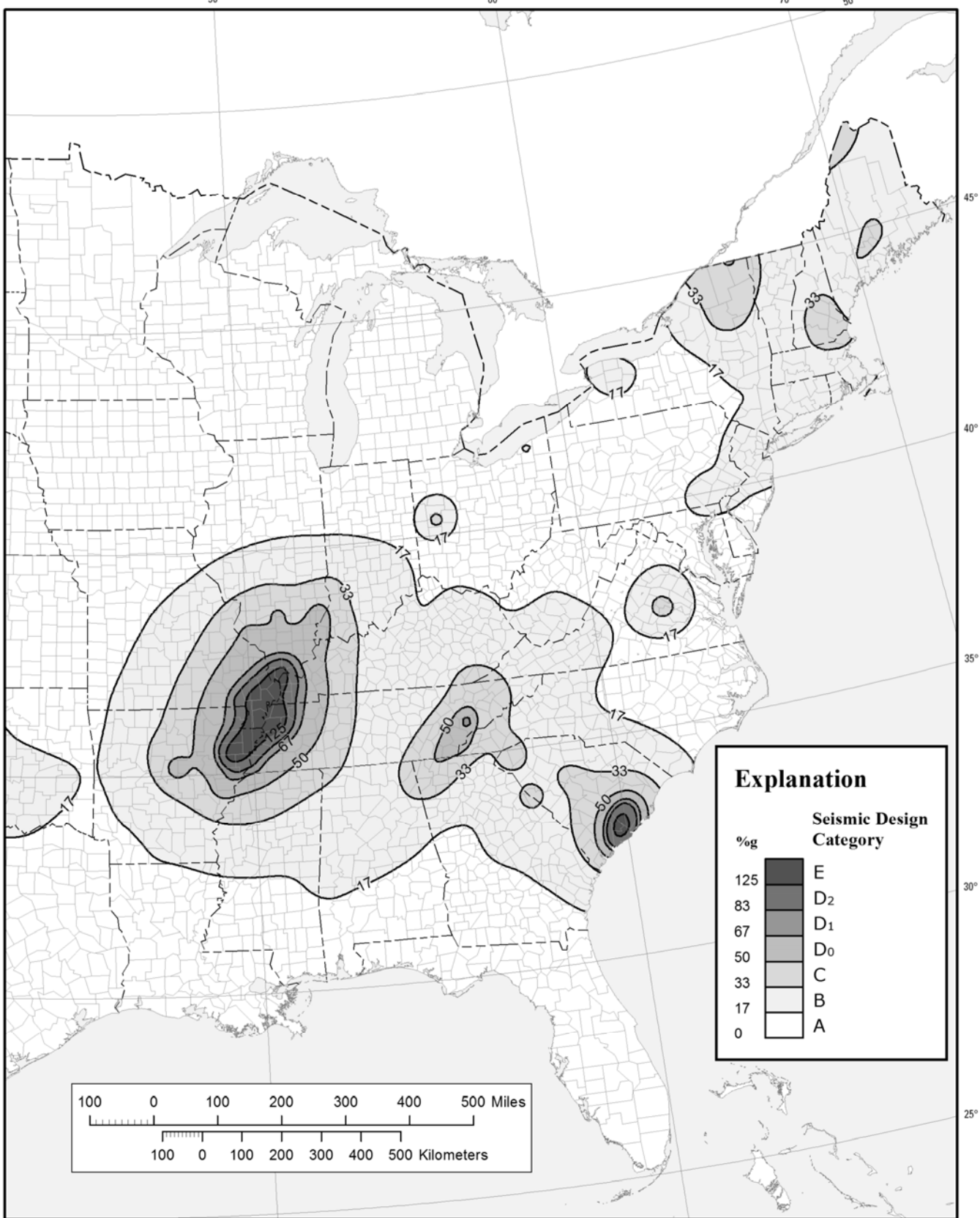

FIGURE 301.2(2)
SEISMIC DESIGN CATEGORIES

DELETED portion of Figure 301.2(2) for Alaska, Hawaii, Puerto Rico and western U.S

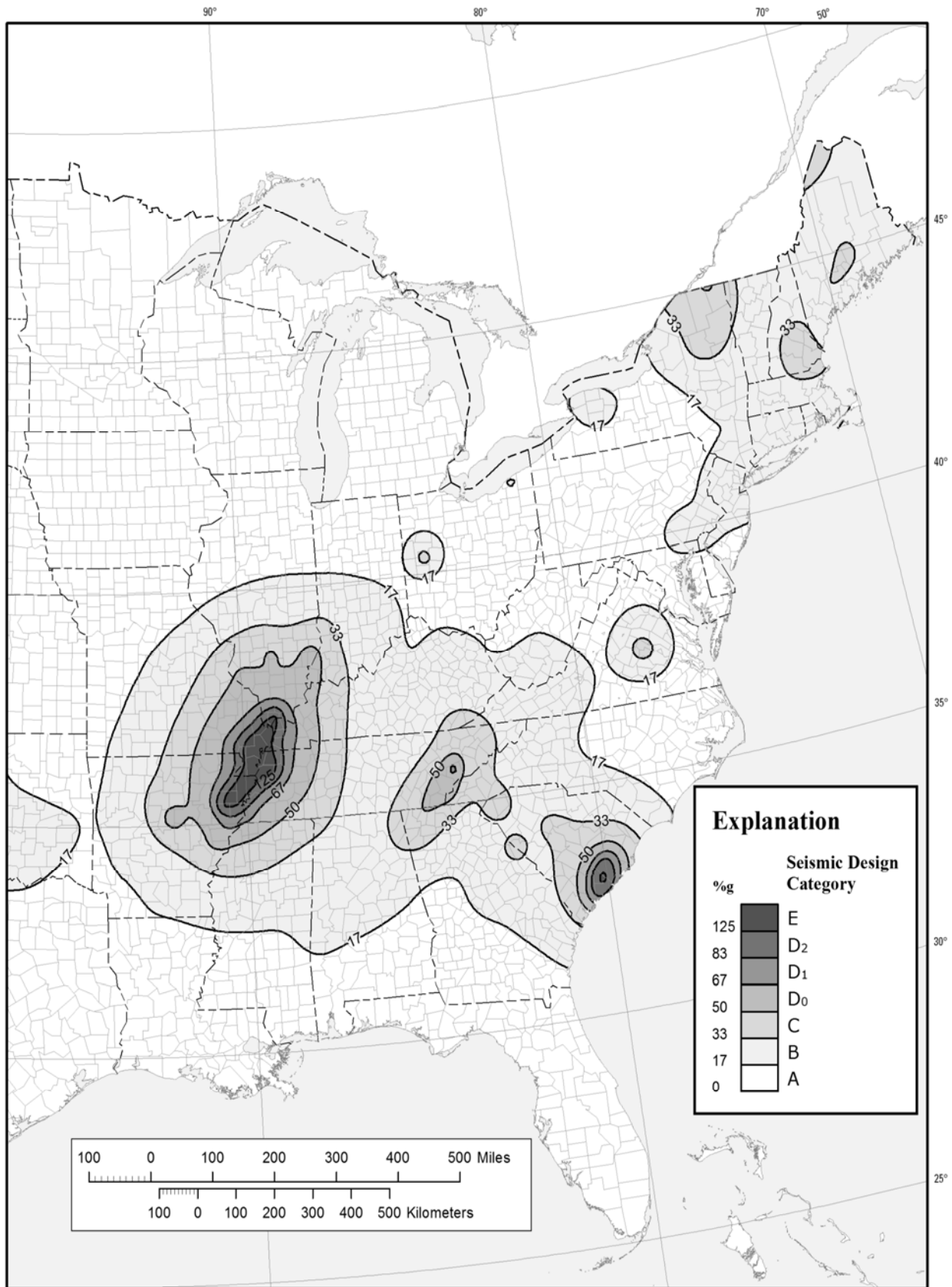
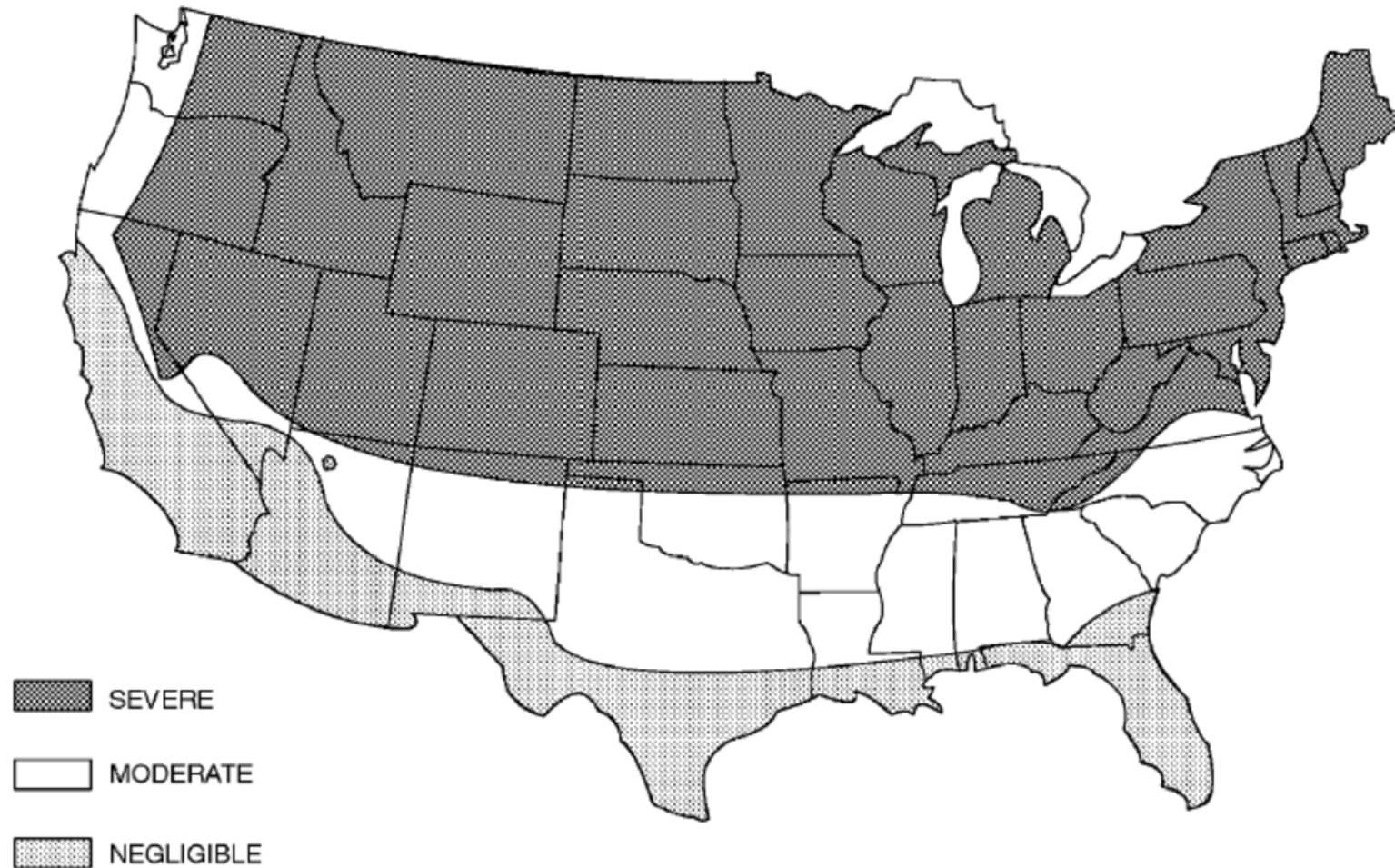

FIGURE 301.2(3)
ALTERNATE SEISMIC DESIGN CATEGORIES

DELETED portion of Figure 301.2(3) for Alaska, Hawaii, Puerto Rico and western U.S



a. Alaska and Hawaii are classified as severe and negligible, respectively.

b. Lines defining areas are approximate only. Local conditions may be more or less severe than indicated by region classification. A severe classification is where weather conditions result in significant snowfall combined with extended periods during which there is little or no natural thawing causing deicing salts to be used extensively.

FIGURE 301.2(4)
WEATHERING PROBABILITY MAP FOR CONCRETE ^{a, b}

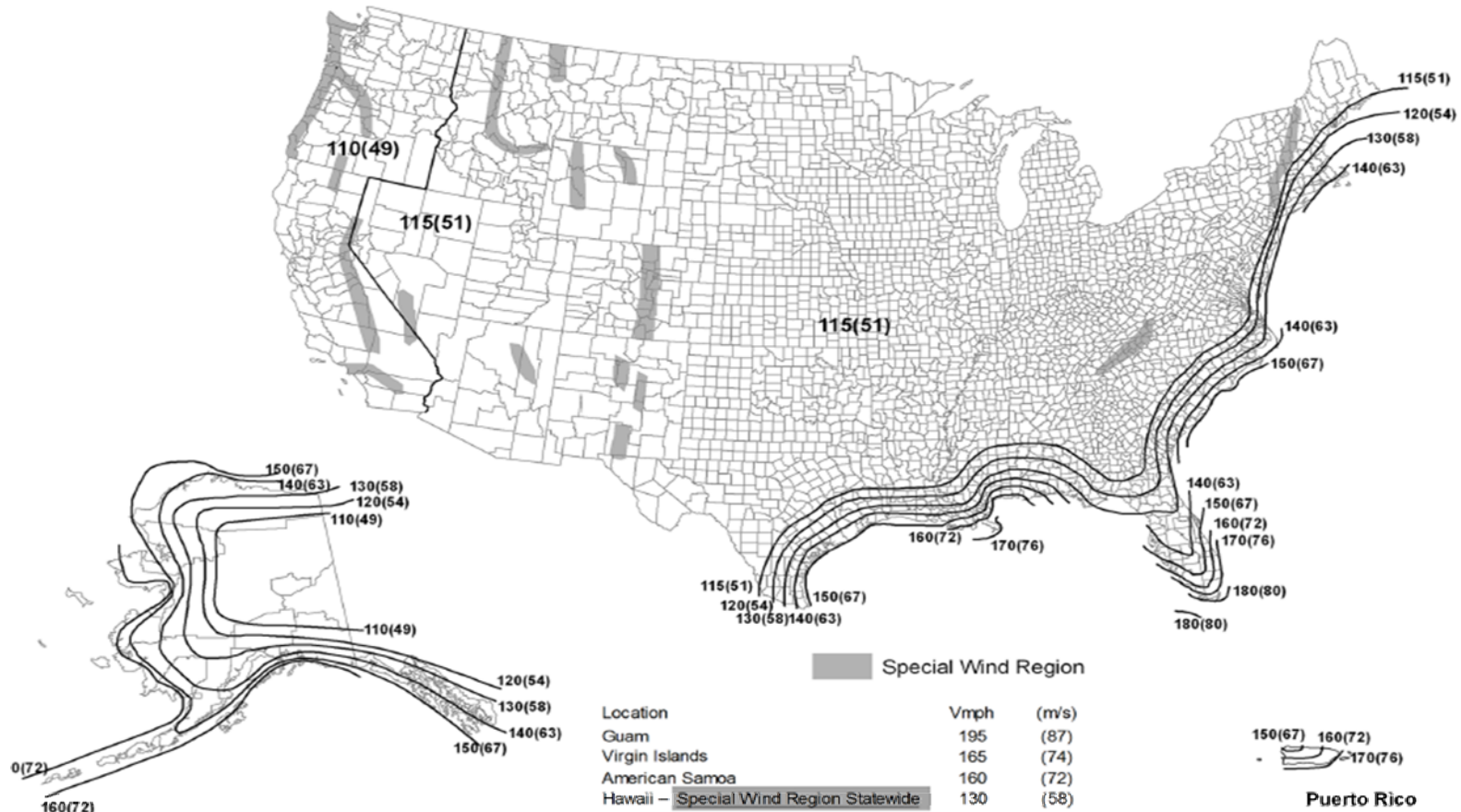

Notes:

1. Values are nominal design 3-second gust wind speeds in miles per hour (m/s) at 33 ft (10m) above ground for Exposure C category.
2. Linear interpolation between contours is permitted.
3. Islands and coastal areas outside the last contour shall use the last wind speed contour of the coastal area.
4. Mountainous terrain, gorges, ocean promontories, and special wind regions shall be examined for unusual wind conditions.
5. Wind speeds correspond to approximately a 7% probability of exceedance in 50 years (Annual Exceedance Probability = 0.00143, MRI = 700 Years).

FIGURE 301.2(5) A
ULTIMATE DESIGN WIND SPEEDS

DELETED Figure 301.2(5)B Regions where wind design is required

D E L E T E D portion of Figure 301.2(6) for western U.S



For SI: 1 foot = 304.8 mm, 1 pound per square foot = 0.0479 kPa, 1 mile = 1.61 km.

- In CS areas, site-specific Case Studies are required to establish ground snow loads. Extreme local variations in ground snow loads in these areas preclude mapping at this scale.
- Numbers in parentheses represent the upper elevation limits in feet for the ground snow load values presented below. Site-specific case studies are required to establish ground snow loads at elevations not covered.

FIGURE 301.2(6)
GROUND SNOW LOADS, P_g, (lb/ft²)
FOR THE EASTERN UNITED STATES

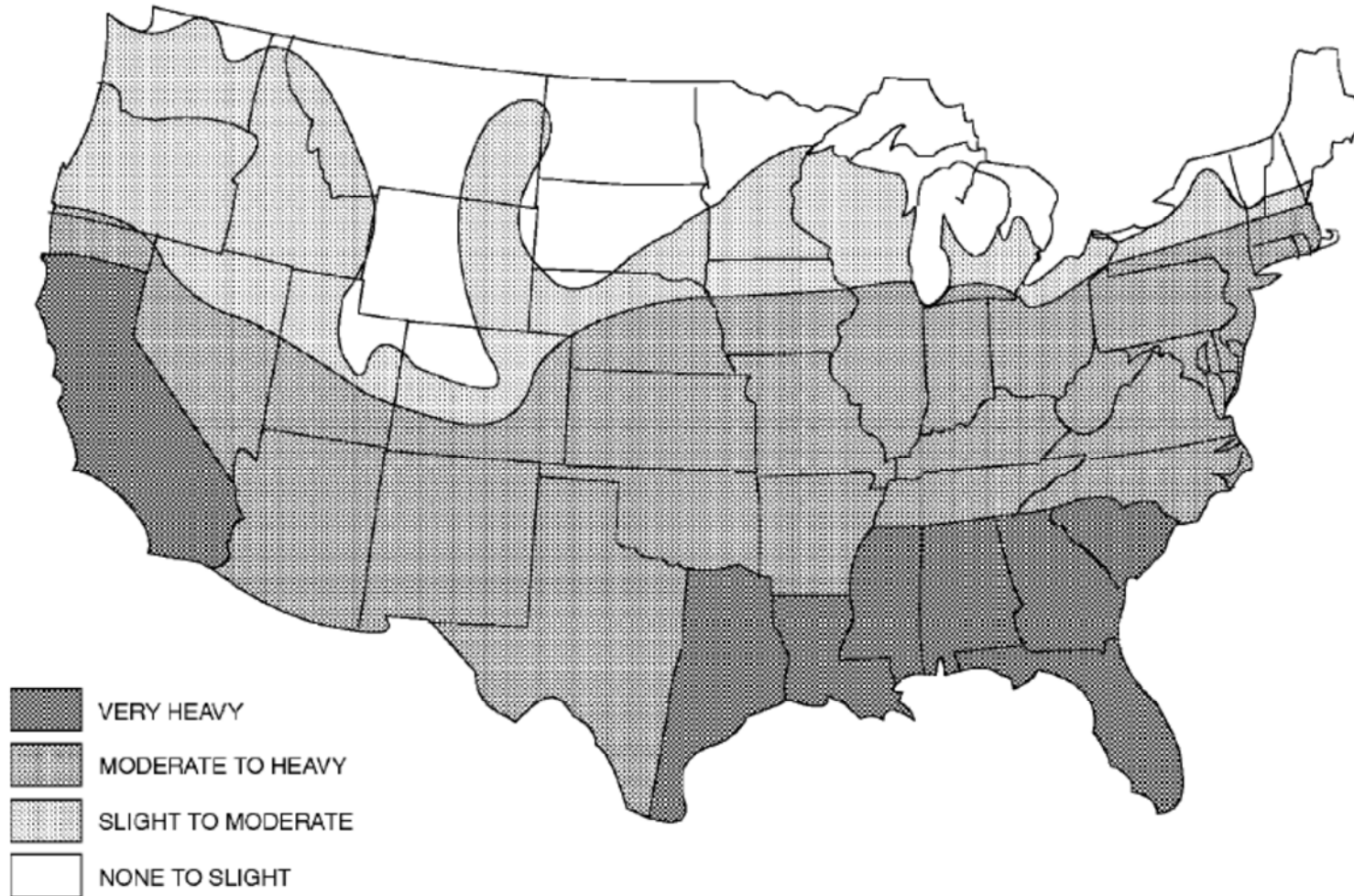

Note: Lines defining areas are approximate only. Local conditions may be more or less severe than indicated by the region classification

FIGURE 301.2(7)
TERMITE INFESTATION PROBABILITY MAP

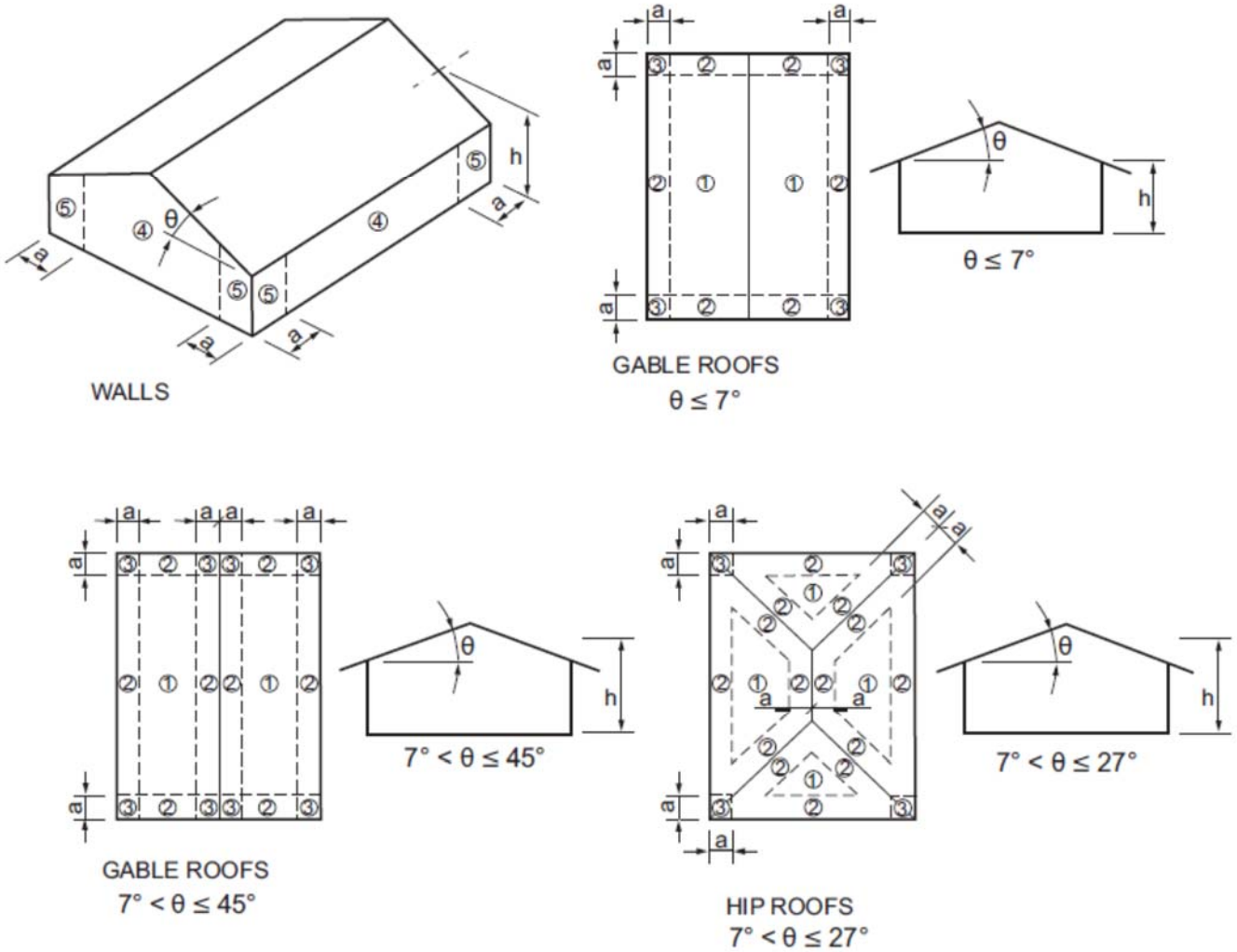

For SI: 1 foot = 304.8 mm, 1 degree = 0.0175 rad.

Note: a = 4 feet in all cases.

FIGURE 301.2(8)
COMPONENT AND CLADDING PRESSURE ZONES

301.2.1.5 Topographic wind effects. Deleted

TABLE 301.2.1.5.1
ULTIMATE DESIGN WIND SPEED MODIFICATION FOR
TOPOGRAPHIC WIND EFFECT^{a, b}

Deleted

Deleted

FIGURE 301.2.1.5.1(1)
TOPOGRAPHIC FEATURES FOR WIND SPEED-UP EFFECT

Deleted

FIGURE 301.2.1.5.1(2)
ILLUSTRATION OF WHERE ON A TOPOGRAPHIC FEATURE,
WIND SPEED INCREASE IS APPLIED

Deleted

FIGURE 301.2.1.5.1(3)
UPWIND OBSTRUCTION

301.2.1.5.1 Simplified topographic wind speed-up method. *Deleted*

301.2.2 Seismic provisions. Buildings in Seismic Design Categories C shall be constructed in accordance with the requirements of this section and other seismic requirements of this code. The seismic provisions of this code shall apply as follows:

1. *Buildings with four or more dwelling units in Seismic Design Categories C.*
2. *Deleted*

Components of buildings not required to be designed to resist seismic loads shall be constructed in accordance with the provisions of this code.

301.2.2.1 Determination of seismic design category. Buildings shall be assigned a seismic design category in accordance with Figure 301.2(2) and Table 301.2.2.1.1

301.2.2.1.1 Alternate determination of seismic design category. The seismic design categories and corresponding short-period design spectral response accelerations, S_{DS} , shown in Figure 301.2(2), are based on soil Site Class D, used as an assumed default, as defined in Section 1613.2 of the *Ohio Building Code*. If soil conditions are determined by the building official to be Site Class A, B, or D, the seismic design category and short-period design spectral response accelerations, S_{DS} , for a site shall be allowed to be determined in accordance with Figure 301.2(3), or Section 1613.3 of the *Ohio Building Code*. The value of S_{DS} determined in accordance with Section

1613.3 of the *Ohio Building Code* is permitted to be used to set the seismic design category in accordance with Table 301.2.2.1.1, and to interpolate between values in Tables 602.10.3(3), 603.9.2(1) and other seismic design requirements of this code.

**TABLE 301.2.2.1.1
SEISMIC DESIGN CATEGORY DETERMINATION**

CALCULATED S_{DS}	SEISMIC DESIGN CATEGORY
$S_{DS} \leq 0.17g$	<u>A</u>
$0.17g < S_{DS} \leq 0.33g$	<u>B</u>
$0.33g < S_{DS} \leq 0.50g$	<u>C</u>

301.2.2.1.2 Alternative determination of Seismic Design Category
E. Deleted

301.2.2.2 Weights of materials. Average dead loads shall not exceed 15 pounds per square foot (720 Pa) for the combined roof and ceiling assemblies (on a horizontal projection) or 10 pounds per square foot (480 Pa) for floor assemblies, except as further limited by Section 301.2.2. Dead loads for walls above grade shall not exceed:

1. Fifteen pounds per square foot (720 Pa) for exterior light-frame wood walls.
2. Fourteen pounds per square foot (670 Pa) for exterior light-frame cold-formed steel walls.
3. Ten pounds per square foot (480 Pa) for interior light-frame wood walls.
4. Five pounds per square foot (240 Pa) for interior light-frame cold-formed steel walls.
5. Eighty pounds per square foot (3830 Pa) for 8-inch-thick (203 mm) masonry walls.
6. Eighty-five pounds per square foot (4070 Pa) for 6-inch-thick (152 mm) concrete walls.
7. Ten pounds per square foot (480 Pa) for SIP walls.

Exceptions:

1. Roof and ceiling dead loads not exceeding 25 pounds per square foot (1190 Pa) shall be permitted provided that the wall bracing amounts in Section 602.10.3 are increased in accordance with Table 602.10.3(4).
2. Light-frame walls with stone or masonry veneer shall be permitted in accordance with the provisions of Sections 702.1 and 703.

3. Fireplaces and chimneys shall be permitted in accordance with Chapter 10.

301.2.2.3 Stone and masonry veneer. Anchored stone and masonry veneer shall comply with the requirements of Sections 702.1 and 703.

301.2.2.4 Masonry construction. *Deleted*

301.2.2.5 Concrete construction. Buildings with exterior above-grade concrete walls shall comply with PCA 100 or shall be designed in accordance with ACI 318.

Exception: Detached one-, two- and three-family dwellings in Seismic Design Category C with exterior above-grade concrete walls are allowed to comply with the requirements of Section 608.

301.2.2.6 Irregular buildings. The seismic provisions of this code shall not be used for structures, or portions thereof, located in Seismic Design Categories C and considered to be irregular in accordance with this section. A building or portion of a building shall be considered to be irregular where one or more of the conditions defined in Items 1 through 7 occur. Irregular structures, or irregular portions of structures, shall be designed in accordance with accepted engineering practice to the extent the irregular features affect the performance of the remaining structural system. Where the forces associated with the irregularity are resisted by a structural system designed in accordance with accepted engineering practice, the remainder of the building shall be permitted to be designed using the provisions of this code.

1. **Shear wall or braced wall offsets out of plane.** Conditions where exterior shear wall lines or braced wall panels are not in one plane vertically from the foundation to the uppermost story in which they are required.

Exception: For wood light-frame construction, floors with cantilevers or setbacks not exceeding four times the nominal depth of the wood floor joists are permitted to support braced wall panels that are out of plane with braced wall panels below provided that all of the following are satisfied:

1. Floor joists are nominal 2 inches by 10 inches (51 mm by 254 mm) or larger and spaced not more than 16 inches (406 mm) on center.
2. The ratio of the back span to the cantilever is not less than 2 to 1.
3. Floor joists at ends of braced wall panels are doubled.

4. For wood-frame construction, a continuous rim joist is connected to ends of cantilever joists. Where spliced, the rim joists shall be spliced using a galvanized metal tie not less than 0.058 inch (1.5 mm) (16 gage) and 11/2 inches (38 mm) wide fastened with six 16d nails on each side of the splice; or a block of the same size as the rim joist and of sufficient length to fit securely between the joist space at which the splice occurs, fastened with eight 16d nails on each side of the splice.
 5. Gravity loads carried at the end of cantilevered joists are limited to uniform wall and roof loads and the reactions from headers having a span of 8 feet (2438 mm) or less.
2. **Lateral support of roofs and floors.** Conditions where a section of floor or roof is not laterally supported by shear walls or braced wall lines on all edges.
- Exception:** Portions of floors that do not support shear walls, braced wall panels above, or roofs shall be permitted to extend not more than 6 feet (1829 mm) beyond a shear wall or braced wall line.
3. **Shear wall or braced wall offsets in plane.** Conditions where the end of a braced wall panel occurs over an opening in the wall below and extends more than 1 foot (305 mm) horizontally past the edge of the opening. This provision is applicable to shear walls and braced wall panels offset in plane and to braced wall panels offset out of plane in accordance with the exception to Item 1.
- Exception:** For wood light-frame wall construction, one end of a braced wall panel shall be permitted to extend more than 1 foot (305 mm) over an opening not more than 8 feet (2438 mm) in width in the wall below provided that the opening includes a header in accordance with all of the following:
1. The building width, loading condition and framing member species limitations of Table 602.7(1) shall apply.
 2. The header is composed of:

 - 2.1 Not less than one 2 × 12 or two 2 × 10 for an opening not more than 4 feet (1219 mm) wide.
 - 2.2 Not less than two 2 × 12 or three 2 × 10 for an opening not more than 6 feet (1829 mm) in width.
 - 2.3 Not less than three 2 × 12 or four 2 × 10 for an opening not more than 8 feet (2438 mm) in width.
 3. The entire length of the braced wall panel does not occur over

an opening in the wall below.

4. **Floor and roof opening.** Conditions where an opening in a floor or roof exceeds the lesser of 12 feet (3658 mm) or 50 percent of the least floor or roof dimension.
5. **Floor level offset.** Conditions where portions of a floor level are vertically offset.

Exceptions:

1. Framing supported directly by continuous foundations at the perimeter of the building.
 2. For wood light-frame construction, floors shall be permitted to be vertically offset where the floor framing is lapped or tied together as required by Section 502.6.1.
6. **Perpendicular shear wall and wall bracing.** Conditions where shear walls and braced wall lines do not occur in two perpendicular directions.
 7. **Wall bracing in stories containing masonry or concrete construction.** Conditions where stories above grade plane are partially or completely braced by wood wall framing in accordance with Section 602 or cold-formed steel wall framing in accordance with Section 603 include masonry or concrete construction. Where this irregularity applies, the entire story shall be designed in accordance with accepted engineering practice.

Exceptions: Fireplaces, chimneys and masonry veneer in accordance with this code.

301.2.2.7 Height limitations. Wood-framed buildings shall be limited to three stories above grade plane or the limits given in Table 602.10.3(3). Cold-formed steel-framed buildings shall be limited to less than or equal to three stories above grade plane in accordance with AISI S230. Mezzanines as defined in Section 202. Structural insulated panel buildings shall be limited to two stories above grade plane.

301.2.2.8 Cold-formed steel framing in Seismic Design Categories D₀, D₁ and D₂. *Deleted*

301.2.2.9 Masonry chimneys. *Deleted*

301.2.2.10 Anchorage of water heaters. *Deleted*

301.2.3 Snow loads. Wood-framed construction, cold-formed, steel-framed construction and masonry and concrete construction, and structural insulated panel construction in regions with ground snow loads 70 pounds per square foot (3.35 kPa) or less, shall be in accordance with Chapters 5, 6 and 8. Buildings in regions with ground snow loads greater than 70 pounds per square foot (3.35 kPa) shall be designed in accordance with accepted engineering practice.

301.2.4 Floodplain construction. Buildings and structures constructed in whole or in part in flood hazard areas (including A or V Zones) as established in Table 301.2(1), and substantial improvement and repair of substantial damage of buildings and structures in flood hazard areas, shall be designed and constructed in accordance with Section 322. Buildings and structures that are located in more than one flood hazard area shall comply with the provisions associated with the most restrictive flood hazard area. Buildings and structures located in whole or in part in identified floodways shall be designed and constructed in accordance with ASCE 24.

301.2.4.1 Alternative provisions. As an alternative to the requirements in Section 322, ASCE 24 is permitted subject to the limitations of this code and the limitations therein.

301.3 Story height. The wind and seismic provisions of this code shall apply to buildings with story heights not exceeding the following:

1. For wood wall framing, the story height shall not exceed 11 feet 7 inches (3531 mm) and the laterally unsupported bearing wall stud height permitted by Table 602.3(5).
2. For cold-formed steel wall framing, the story height shall be not more than 11 feet 7 inches (3531 mm) and the unsupported bearing wall stud height shall be not more than 10 feet (3048 mm).
3. For masonry walls, the story height shall be not more than 13 feet 7 inches (4140 mm) and the bearing wall clear height shall be not more than 12 feet (3658 mm).

Exception: An additional 8 feet (2438 mm) of bearing wall clear height is permitted for gable end walls.
4. For insulating concrete form walls, the maximum story height shall not exceed 11 feet 7 inches (3531 mm) and the maximum unsupported wall height per story as permitted by Section 608 tables shall not exceed 10 feet (3048 mm).
5. For structural insulated panel (SIP) walls, the story height shall be not more than 11 feet 7 inches (3531 mm) and the bearing wall height per

story as permitted by Section 610 tables shall not exceed 10 feet (3048 mm).

Individual walls or wall studs shall be permitted to exceed these limits as permitted by Chapter 6 provisions, provided that story heights are not exceeded. An engineered design shall be provided for the wall or wall framing members where the limits of Chapter 6 are exceeded. Where the story height limits of this section are exceeded, the design of the building, or the noncompliant portions thereof, to resist wind and seismic loads shall be in accordance with the *Ohio building code*.

301.4 Dead load. The actual weights of materials and construction shall be used for determining dead load with consideration for the dead load of fixed service equipment.

301.5 Live load. The minimum uniformly distributed live load shall be as provided in Table 301.5.

TABLE 301.5
MINIMUM UNIFORMLY DISTRIBUTED LIVE LOADS
(in pounds per square foot)

<u>USE</u>	<u>LIVE LOAD</u>
<u>Uninhabitable attics without storage^b</u>	<u>10</u>
<u>Uninhabitable attics with limited storage^{b, g}</u>	<u>20</u>
<u>Habitable attics and attics served with fixed stairs</u>	<u>30</u>
<u>Balconies (exterior) and decks^e</u>	<u>40</u>
<u>Fire escapes</u>	<u>40</u>
<u>Guards and handrails^d</u>	<u>200^h</u>
<u>Guard in-fill components^f</u>	<u>50^h</u>
<u>Passenger vehicle garages^a</u>	<u>50^a</u>
<u>Rooms other than sleeping rooms</u>	<u>40</u>
<u>Sleeping rooms</u>	<u>30</u>
<u>Stairs</u>	<u>40^c</u>

For SI: 1 pound per square foot = 0.0479 kPa, 1 square inch = 645 mm², 1 pound = 4.45 N.

- a. Elevated garage floors shall be capable of supporting a 2,000-pound load applied over a 20-square-inch area.
- b. Uninhabitable attics without storage are those where the clear height between joists and rafters is not more than 42 inches, or where there are not two or more adjacent trusses with web configurations capable of accommodating an assumed rectangle 42 inches in height by 24 inches in width, or greater, within the plane of the trusses. This live load need not be assumed to act concurrently with any other live load requirements.
- c. Individual stair treads shall be designed for the uniformly distributed live load or a 300-pound concentrated load acting over an area of 4 square inches, whichever produces the greater stresses.
- d. A single concentrated load applied in any direction at any point along the top.
- e. See Section 507.1 for decks attached to exterior walls.
- f. Guard in-fill components (all those except the handrail), balusters and panel fillers shall be designed to withstand a horizontally applied normal load of 50 pounds on an area equal to 1 square foot. This load need not be assumed to act concurrently with any other live load requirement.
- g. Uninhabitable attics with limited storage are those where the clear height between joists and rafters is 42 inches or greater, or where there are two or more adjacent trusses with web configurations capable of

accommodating an assumed rectangle 42 inches in height by 24 inches in width, or greater, within the plane of the trusses.

The live load need only be applied to those portions of the joists or truss bottom chords where all of the following conditions are met:

1. The attic area is accessed from an opening not less than 20 inches in width by 30 inches in length that is located where the clear height in the attic is not less than 30 inches.
 2. The slopes of the joists or truss bottom chords are not greater than 2 inches vertical to 12 units horizontal.
 3. Required insulation depth is less than the joist or truss bottom chord member depth.
The remaining portions of the joists or truss bottom chords shall be designed for a uniformly distributed concurrent live load of not less than 10 pounds per square foot.
- h. Glazing used in handrail assemblies and guards shall be designed with a safety factor of 4. The safety factor shall be applied to each of the concentrated loads applied to the top of the rail, and to the load on the infill components. These loads shall be determined independent of one another, and loads are assumed not to occur with any other live load.

301.6 Roof load. The roof shall be designed for the live load indicated in Table 301.6 or the snow load indicated in Table 301.2(1), whichever is greater.

**TABLE 301.6
 MINIMUM ROOF LIVE LOADS IN POUNDS-FORCE PER
 SQUARE FOOT OF HORIZONTAL PROJECTION**

ROOF SLOPE	TRIBUTARY LOADED AREA IN SQUARE FEET FOR ANY STRUCTURAL MEMBER		
	0 to 200	201 to 600	Over 600
<u>Flat or rise less than 4 inches per foot (1:3)</u>	<u>20</u>	<u>16</u>	<u>12</u>
<u>Rise 4 inches per foot (1:3) to less than 12 inches per foot (1:1)</u>	<u>16</u>	<u>14</u>	<u>12</u>
<u>Rise 12 inches per foot (1:1) and greater</u>	<u>12</u>	<u>12</u>	<u>12</u>

For SI: 1 square foot = 0.0929 m², 1 pound per square foot = 0.0479 kPa, 1 inch per foot = 83.3 mm/m.

301.7 Deflection. The allowable deflection of any structural member under the live load listed in Sections 301.5 and 301.6 or wind loads determined by Section 301.2.1 shall not exceed the values in Table 301.7.

**TABLE 301.7
 ALLOWABLE DEFLECTION OF STRUCTURAL MEMBERS^{b, c}**

STRUCTURAL MEMBER	ALLOWABLE DEFLECTION
<u>Rafters having slopes greater than 3:12 with finished ceiling not attached to rafters</u>	<u>L/180</u>
<u>Interior walls and partitions</u>	<u>H/180</u>
<u>Floors</u>	<u>L/360</u>
<u>Ceilings with brittle finishes (including plaster and stucco)</u>	<u>L/360</u>
<u>Ceilings with flexible finishes (including gypsum board)</u>	<u>L/240</u>
<u>All other structural members</u>	<u>L/240</u>
<u>Exterior walls—wind loads^a with plaster or stucco finish</u>	<u>H/360</u>

Exterior walls—wind loads ^a with other brittle finishes	$H/240$
Exterior walls—wind loads ^a with flexible finishes	$H/120^d$
Lintels supporting masonry veneer walls ^e	$L/600$

Note: L = span length, H = span height.

- a. For the purpose of the determining deflection limits herein, the wind load shall be permitted to be taken as 0.7 times the component and cladding (ASD) loads obtained from Table 301.2(2).
- b. For cantilever members, L shall be taken as twice the length of the cantilever.
- c. For aluminum structural members or panels used in roofs or walls of sunroom additions or patio covers, not supporting edge of glass or sandwich panels, the total load deflection shall not exceed $L/60$. For continuous aluminum structural members supporting edge of glass, the total load deflection shall not exceed $L/175$ for each glass lite or $L/60$ for the entire length of the member, whichever is more stringent. For sandwich panels used in roofs or walls of sunroom additions or patio covers, the total load deflection shall not exceed $L/120$.
- d. Deflection for exterior walls with interior gypsum board finish shall be limited to an allowable deflection of $H/180$.
- e. Refer to Section 703.8.2.

301.8 Nominal sizes. For the purposes of this code, dimensions of lumber specified shall be deemed to be nominal dimensions unless specifically designated as actual dimensions.

SECTION 302 **FIRE-RESISTANT CONSTRUCTION**

302.1 Exterior walls. Construction, projections, openings and penetrations of exterior walls of dwellings and accessory buildings shall comply with Table 302.1(1); or dwellings equipped throughout with an automatic sprinkler system installed in accordance with Section 2904 shall comply with Table 302.1(2).

Exceptions:

1. Walls, projections, openings or penetrations in walls perpendicular to the line used to determine the fire separation distance.
2. Walls of individual dwelling units and their accessory structures located on the same lot.
3. Detached tool sheds and storage sheds, playhouses and similar structures exempted from approval by Section 102.10 are not required to provide wall protection based on location on the lot. Projections beyond the exterior wall shall not extend over the lot line.
4. Detached garages accessory to a dwelling located within 2 feet (610 mm) of a lot line are permitted to have roof eave projections not exceeding 4 inches (102 mm).
5. Foundation vents installed in compliance with this code are permitted.
6. Detached garages accessory to a dwelling with an exterior wall located greater than or equal to 3 feet from a lot line.

Where referenced in this code, an unoccupied space on an adjoining property

may be included in the required fire separation distance, provided that the adjoining property is dedicated or deeded so as to preclude, for the life of the structure, the erection of any building or structure on such space (see section 3781.02 of the Revised Code).

**TABLE 302.1(1)
EXTERIOR WALLS**

<u>EXTERIOR WALL ELEMENT</u>		<u>MINIMUM FIRE-RESISTANCE RATING</u>	<u>MINIMUM FIRE SEPARATION DISTANCE</u>
<u>Walls</u>	<u>Fire-resistance rated</u>	<u>1 hour—tested in accordance with ASTM E119, UL 263 or Section 703.3 of the Ohio building code with exposure from both sides</u>	<u>0 feet</u>
	<u>Not fire-resistance rated</u>	<u>0 hours</u>	<u>≥5 feet</u>
<u>Projections</u>	<u>Not allowed</u>	<u>N/A</u>	<u>< 2 feet</u>
	<u>Fire-resistance rated</u>	<u>1 hour on the underside, or heavy timber, or fire-retardant-treated wood^{a, b}</u>	<u>≥2 feet to < 5 feet</u>
	<u>Not fire-resistance rated</u>	<u>0 hours</u>	<u>≥5 feet</u>
<u>Openings in walls</u>	<u>Not allowed</u>	<u>N/A</u>	<u>< 3 feet</u>
	<u>25% maximum of wall area</u>	<u>0 hours</u>	<u>3 feet</u>
	<u>Unlimited</u>	<u>0 hours</u>	<u>5 feet</u>
<u>Penetrations</u>	<u>All</u>	<u>Comply with Section 302.4</u>	<u>< 3 feet</u>
		<u>None required</u>	<u>3 feet</u>

For SI: 1 foot = 304.8 mm. N/A = Not Applicable.

- a. The fire-resistance rating shall be permitted to be reduced to 0 hours on the underside of the eave overhang if fireblocking is provided from the wall top plate to the underside of the roof sheathing.
- b. The fire-resistance rating shall be permitted to be reduced to 0 hours on the underside of the rake overhang where gable vent openings are not installed.

**TABLE 302.1(2)
EXTERIOR WALLS—DWELLINGS WITH FIRE SPRINKLERS**

<u>EXTERIOR WALL ELEMENT</u>		<u>MINIMUM FIRE-RESISTANCE RATING</u>	<u>MINIMUM FIRE SEPARATION DISTANCE</u>
<u>Walls</u>	<u>Fire-resistance rated</u>	<u>1 hour—tested in accordance with ASTM E119, UL 263 or Section 703.3 of the Ohio building code with exposure from the outside</u>	<u>0 feet</u>
	<u>Not fire-resistance rated</u>	<u>0 hours</u>	<u>3 feet^a</u>
<u>Projections</u>	<u>Not allowed</u>	<u>N/A</u>	<u>< 2 feet</u>
	<u>Fire-resistance rated</u>	<u>1 hour on the underside, or heavy timber, or fire-retardant-treated wood^{b, c}</u>	<u>2 feet^a</u>
	<u>Not fire-resistance rated</u>	<u>0 hours</u>	<u>3 feet</u>
<u>Openings in walls</u>	<u>Not allowed</u>	<u>N/A</u>	<u>< 3 feet</u>
	<u>Unlimited</u>	<u>0 hours</u>	<u>3 feet^a</u>
<u>Penetrations</u>	<u>All</u>	<u>Comply with Section 302.4</u>	<u>< 3 feet</u>

		<u>None required</u>	<u>3 feet^a</u>
--	--	----------------------	---------------------------

For SI: 1 foot = 304.8 mm. N/A = Not Applicable.

- a. For residential subdivisions where all dwellings are equipped throughout with an automatic sprinkler system installed in accordance with Section 2904, the fire separation distance for exterior walls not fire-resistance rated and for fire-resistance-rated projections shall be permitted to be reduced to 0 feet, and unlimited unprotected openings and penetrations shall be permitted, where the adjoining lot provides an open setback yard that is 6 feet or more in width on the opposite side of the property line.
- b. The fire-resistance rating shall be permitted to be reduced to 0 hours on the underside of the eave overhang if fireblocking is provided from the wall top plate to the underside of the roof sheathing.
- c. The fire-resistance rating shall be permitted to be reduced to 0 hours on the underside of the rake overhang where gable vent openings are not installed.

302.2 Residential structures with more than two dwelling units. In structures with more than two dwelling units, each grouping of two dwelling units shall be separated from an adjacent dwelling unit or an adjacent grouping of two dwelling units by two wall assemblies, each having a fire resistance rating of one hour when tested in accordance with ASTM E119 or UL 263 and/or a floor ceiling assembly having a fire resistance rating of two hours when tested in accordance with ASTM E119 or UL 263.

Alternatively, each grouping of two dwelling units shall be separated from an adjacent dwelling unit or an adjacent grouping of two dwelling units by a common wall assembly having a fire resistance rating of not less than two hours when tested in accordance with ASTM E119 or UL 263 and/or a floor ceiling assembly having a fire resistance rating of two hours when tested in accordance with ASTM E119 or UL 263. This option is only permissible if the common wall does not contain plumbing or mechanical equipment, ducts or vents in the cavity of the common wall. The common wall shall be rated for fire exposure from both sides and shall extend to and be tight against exterior walls and the underside of the roof sheathing. Penetrations of electrical outlet boxes shall be in accordance with Section 302.4.

Additionally, within any grouping of two dwelling units, separated as indicated above, the individual dwelling units shall be separated vertically and horizontally from adjacent dwelling units by wall and/or floor assemblies having a fire resistance rating of not less than one hour when tested in accordance with ASTM E119 or UL 263.

When assemblies are required to be fire-resistance-rated, the supporting construction of such assemblies shall have an equal or greater fire-resistive rating.

302.2.1 Double walls. Deleted

302.2.2 Common walls. Deleted

302.2.3 Continuity. The fire-resistance-rated wall or assembly separating dwelling units shall be continuous from the foundation to the underside of the roof sheathing, deck or slab. The fire-resistance rating shall extend the full length of the wall or assembly, including wall extensions through and separating attached enclosed accessory structures.

302.2.4 Parapets. Parapets constructed in accordance with Section 302.2.5 shall be constructed for dwellings units as an extension of exterior walls or common walls in accordance with the following:

1. Where roof surfaces adjacent to the wall or walls are at the same elevation, the parapet shall extend not less than 30 inches (762 mm) above the roof surfaces.
2. Where roof surfaces adjacent to the wall or walls are at different elevations and the higher roof is not more than 30 inches (762 mm) above the lower roof, the parapet shall extend not less than 30 inches (762 mm) above the lower roof surface.

Exception: A parapet is not required in the preceding two cases where the roof covering complies with a minimum Class C rating as tested in accordance with ASTM E108 or UL 790 and the roof decking or sheathing is of noncombustible materials or fire-retardant-treated wood for a distance of 4 feet (1219 mm) on each side of the wall or walls, or one layer of ⁵/₈ inch (15.9 mm) Type X gypsum board is installed directly beneath the roof decking or sheathing, supported by not less than nominal 2-inch (51 mm) ledgers attached to the sides of the roof framing members, for a distance of not less than 4 feet (1219 mm) on each side of the wall or walls and any openings or penetrations in the roof are not within 4 feet (1219 mm) of the common walls. Fire-retardant-treated wood shall meet the requirements of Sections 802.1.5 and 803.2.1.2.

3. A parapet is not required where roof surfaces adjacent to the wall or walls are at different elevations and the higher roof is more than 30 inches (762 mm) above the lower roof. The common wall construction from the lower roof to the underside of the higher roof deck shall have not less than a 1-hour fire-resistance rating. The wall shall be rated for exposure from both sides.

302.2.5 Parapet construction. Parapets shall have the same fire-resistance rating as that required for the supporting wall or walls. On any side adjacent to a roof surface, the parapet shall have noncombustible faces for the uppermost 18 inches (457 mm), to include counterflashing and coping materials. Where the

roof slopes toward a parapet at slopes greater than 2 units vertical in 12 units horizontal (16.7-percent slope), the parapet shall extend to the same height as any portion of the roof within a distance of 3 feet (914 mm), and the height shall be not less than 30 inches (762 mm).

302.2.6 Structural independence. Each individual *dwelling unit* shall be structurally independent.

Exceptions:

1. Foundations supporting exterior walls or common walls.
2. Structural roof and wall sheathing from each unit fastened to the common wall framing.
3. Nonstructural wall and roof coverings.
4. Flashing at termination of roof covering over common wall.
5. *Dwelling units* separated by a common wall as provided in Section 302.2.2, Item 1 or 2.
6. *Dwelling units stacked vertically.*

302.3 Two-family dwellings. Dwelling units in two-family dwellings shall be separated from each other by wall and floor assemblies having not less than a 1-hour fire-resistance rating where tested in accordance with ASTM E119, UL 263 or Section 703.3 of the *Ohio building code*. Fire-resistance-rated floor/ceiling and wall assemblies shall extend to and be tight against the exterior wall, and wall assemblies shall extend from the foundation to the underside of the roof sheathing.

Exceptions:

1. A fire-resistance rating of 1/2-hour shall be permitted in buildings equipped throughout with an automatic sprinkler system installed in accordance with NFPA 13.
2. Wall assemblies need not extend through attic spaces where the ceiling is protected by not less than 5/8-inch (15.9 mm) Type X gypsum board, an attic draft stop constructed as specified in Section 302.12.1 is provided above and along the wall assembly separating the dwellings and the structural framing supporting the ceiling is protected by not less than 1/2-inch (12.7 mm) gypsum board or equivalent *and the dwelling is equipped throughout with an automatic sprinkler system installed in accordance with NFPA 13D.*

302.3.1 Supporting construction. Where floor assemblies are required to be fire-resistance rated by Section 302.3, the supporting construction of such assemblies shall have an equal or greater fire-resistance rating.

302.4 Dwelling unit rated penetrations. Penetrations of wall or floor-ceiling assemblies required to be fire-resistance rated in accordance with Section 302.2

or 302.3 shall be protected in accordance with this section.

302.4.1 Through penetrations. Through penetrations of fire-resistance-rated wall or floor assemblies shall comply with Section 302.4.1.1 or 302.4.1.2.

Exception: Where the penetrating items are steel, ferrous or copper pipes, tubes or conduits, the annular space shall be protected as follows:

1. In concrete or masonry wall or floor assemblies, concrete, grout or mortar shall be permitted where installed to the full thickness of the wall or floor assembly or the thickness required to maintain the fire-resistance rating, provided that both of the following are complied with:
 - 1.1. The nominal diameter of the penetrating item is not more than 6 inches (152 mm).
 - 1.2. The area of the opening through the wall does not exceed 144 square inches (92,900 mm²).
2. The material used to fill the annular space shall prevent the passage of flame and hot gases sufficient to ignite cotton waste where subjected to ASTM E119 or UL 263 time temperature fire conditions under a positive pressure differential of not less than 0.01 inch of water (3 Pa) at the location of the penetration for the time period equivalent to the fire-resistance rating of the construction penetrated.

302.4.1.1 Fire-resistance-rated assembly. Penetrations shall be installed as tested in the approved fire resistance-rated assembly.

302.4.1.2 Penetration firestop system. Penetrations shall be protected by an approved penetration firestop system installed as tested in accordance with ASTM E814 or UL 1479, with a positive pressure differential of not less than 0.01 inch of water (3 Pa) and shall have an F rating of not less than the required fire-resistance rating of the wall or floor-ceiling assembly penetrated.

302.4.2 Membrane penetrations. Membrane penetrations shall comply with Section 302.4.1. Where walls are required to have a fire-resistance rating, recessed fixtures shall be installed so that the required fire-resistance rating will not be reduced.

Exceptions:

1. Membrane penetrations of not more than 2-hour fire-resistance-rated walls and partitions by steel electrical boxes that do not exceed 16 square inches (0.0103 m²) in area provided that the aggregate area of the openings through the membrane does not exceed 100 square inches (0.0645 m²) in any 100 square feet (9.29 m²) of wall area. The annular

space between the wall membrane and the box shall not exceed $\frac{1}{8}$ inch (3.1 mm). Such boxes on opposite sides of the wall shall be separated by one of the following:

- 1.1. By a horizontal distance of not less than 24 inches (610 mm) where the wall or partition is constructed with individual noncommunicating stud cavities.
- 1.2. By a horizontal distance of not less than the depth of the wall cavity where the wall cavity is filled with cellulose loose-fill, rockwool or slag mineral wool insulation.
- 1.3. By solid fireblocking in accordance with Section 302.11.
- 1.4. By protecting both boxes with listed putty pads.
- 1.5. By other listed materials and methods.
2. Membrane penetrations by listed electrical boxes of any materials provided that the boxes have been tested for use in fire-resistance-rated assemblies and are installed in accordance with the instructions included in the listing. The annular space between the wall membrane and the box shall not exceed $\frac{1}{8}$ inch (3.1 mm) unless listed otherwise. Such boxes on opposite sides of the wall shall be separated by one of the following:
 - 2.1. By the horizontal distance specified in the listing of the electrical boxes.
 - 2.2. By solid fireblocking in accordance with Section 302.11.
 - 2.3. By protecting both boxes with listed putty pads.
 - 2.4. By other listed materials and methods
3. The annular space created by the penetration of a fire sprinkler provided that it is covered by a metal escutcheon plate.
4. Ceiling membrane penetrations by listed *and labeled* luminaires or by luminaires protected with listed materials that have been tested for use in fire resistance-rated assemblies and are installed in accordance with the instructions included in the listing.

302.5 Dwelling-garage opening and penetration protection. Openings and penetrations through the walls or ceilings separating the dwelling from the garage shall be in accordance with Sections 302.5.1 through 302.5.3.

302.5.1 Opening protection. Openings from a private garage directly into a room used for sleeping purposes shall not be permitted. Other openings between the garage and residence shall be equipped with solid wood doors not less than $1\frac{3}{8}$ inches (35 mm) in thickness, solid or honeycomb-core steel doors not less than $1\frac{3}{8}$ inches (35 mm) thick, or 20-minute fire-rated doors.

302.5.2 Duct penetration. Ducts in the garage and ducts penetrating the walls or ceilings separating the dwelling from the garage shall be constructed of a minimum No. 26 gage (0.48 mm) sheet steel or other approved material and shall not have openings into the garage.

302.5.3 Other penetrations. Penetrations through the separation required in Section 302.6 shall be protected as required by Section 302.11, Item 4.

302.6 Dwelling-garage fire separation. The garage shall be separated as required by Table 302.6. Openings in garage walls shall comply with Section 302.5. Attachment of gypsum board shall comply with Table 702.3.5. The wall separation provisions of Table 302.6 shall not apply to garage walls that are perpendicular to the adjacent dwelling unit wall.

**TABLE 302.6
DWELLING-GARAGE SEPARATION ¹**

<u>SEPARATION</u>	<u>MATERIAL</u>
<u>From the residence and attics</u>	<u>Not less than 1/2 -inch gypsum board or equivalent applied to the garage side</u>
<u>From habitable rooms above the garage</u>	<u>Not less than 5/8 -inch Type X gypsum board or equivalent</u>
<u>Structure(s) supporting floor/ceiling assemblies used for separation required by this section</u>	<u>Not less than 1/2 -inch gypsum board or equivalent</u>
<u>Garages located less than 3 feet from a dwelling unit on the same lot</u>	<u>Not less than 1/2 -inch gypsum board or equivalent applied to the interior side of exterior walls that are within this area</u>

For SI: 1 inch = 25.4 mm, 1 foot = 304.8 mm.

1. To determine fire resistance equivalents, refer to section 302.14

302.7 Under-stair protection. Enclosed space under stairs that is accessed by a door or access panel shall have walls, under-stair surface and any soffits protected on the enclosed side with 1/2 -inch (12.7 mm) gypsum board.

302.8 Foam plastics. For requirements for foam plastics, see Section 316.

302.9 Flame spread index and smoke-developed index for wall and ceiling finishes. Flame spread and smoke- developed indices for wall and ceiling finishes shall be in accordance with Sections 302.9.1 through 302.9.4.

302.9.1 Flame spread index. Wall and ceiling finishes shall have a flame spread index of not greater than 200.

Exception: Flame spread index requirements for finishes shall not apply to trim defined as picture molds, chair rails, baseboards and handrails; to doors and windows or their frames; or to materials that are less than 1/28 -inch (0.91 mm) in thickness cemented to the surface of walls or ceilings if these materials

exhibit flame spread index values not greater than those of paper of this thickness cemented to a noncombustible backing.

302.9.2 Smoke-developed index. Wall and ceiling finishes shall have a smoke-developed index of not greater than 450.

302.9.3 Testing. Tests shall be made in accordance with ASTM E84 or UL 723.

302.9.4 Alternative test method. As an alternative to having a flame spread index of not greater than 200 and a smoke-developed index of not greater than 450 where tested in accordance with ASTM E84 or UL 723, wall and ceiling finishes shall be permitted to be tested in accordance with NFPA 286. Materials tested in accordance with NFPA 286 shall meet the following criteria:

The interior finish shall comply with the following:

1. During the 40 kW exposure, flames shall not spread to the ceiling.
2. The flame shall not spread to the outer extremity of the sample on any wall or ceiling.
3. Flashover, as defined in NFPA 286, shall not occur.
4. The peak heat release rate throughout the test shall not exceed 800 kW.
5. The total smoke released throughout the test shall not exceed 1,000 m².

302.10 Flame spread index and smoke-developed index for insulation. Flame spread and smoke-developed index for insulation shall be in accordance with Sections 302.10.1 through 302.10.5.

302.10.1 Insulation. Insulating materials installed within floor-ceiling assemblies, roof-ceiling assemblies, wall assemblies, crawl spaces and attics shall comply with the requirements of this section. They shall exhibit a flame spread index not to exceed 25 and a smoke-developed index not to exceed 450 where tested in accordance with ASTM E84 or UL 723. Insulating materials, where tested in accordance with the requirements of this section, shall include facings, where used, such as vapor retarders, vapor permeable membranes and similar coverings.

Exceptions:

1. Where such materials are installed in concealed spaces, the flame spread index and smoke-developed index limitations do not apply to the facings, provided that the facing is installed in substantial contact with the unexposed surface of the ceiling, floor or wall finish.

2. Cellulose fiber loose-fill insulation that is not spray applied and that complies with the requirements of Section 302.10.3 shall not be required to meet the flame spread index requirements but shall be required to meet a smoke-developed index of not more than 450 where tested in accordance with CAN/ULC S102.2.
3. Foam plastic insulation shall comply with Section 316.

302.10.2 Loose-fill insulation. Loose-fill insulation materials that cannot be mounted in the ASTM E84 or UL723 apparatus without a screen or artificial supports shall comply with the flame spread and smoke-developed limits of Section 302.10.1 where tested in accordance with CAN/ULC S102.2.

Exception: Cellulosic fiber loose-fill insulation shall not be required to be tested in accordance with CAN/ULC S102.2, provided that such insulation complies with the requirements of Sections 302.10.1 and 302.10.3.

302.10.3 Cellulosic fiber loose-fill insulation. Cellulosic fiber loose-fill insulation shall comply with CPSC 16 CFR, Parts 1209 and 1404. Each package of such insulating material shall be clearly *labeled* in accordance with CPSC 16 CFR, Parts 1209 and 1404.

302.10.4 Exposed attic insulation. Exposed insulation materials installed on attic floors shall have a critical radiant flux of not less than 0.12 watt per square centimeter.

302.10.5 Testing. Tests for critical radiant flux shall be made in accordance with ASTM E970.

302.11 Fireblocking. In combustible construction, fireblocking shall be provided to cut off both vertical and horizontal concealed draft openings and to form an effective fire barrier between stories, and between a top story and the roof space.

Fireblocking shall be provided in wood-framed construction in the following locations:

1. In concealed spaces of stud walls and partitions, including furred spaces and parallel rows of studs or staggered studs, as follows:
 - 1.1. Vertically at the ceiling and floor levels.
 - 1.2. Horizontally at intervals not exceeding 10 feet (3048 mm).
2. At interconnections between concealed vertical and horizontal spaces such as occur at soffits, drop ceilings and cove ceilings.
3. In concealed spaces between stair stringers at the top and bottom of the run. Enclosed spaces under stairs shall comply with Section 302.7.
4. At openings around vents, pipes, ducts, cables and wires at ceiling and floor

level, with an approved material to resist the free passage of flame and products of combustion. The material filling this annular space shall not be required to meet the ASTM E136 requirements.

5. For the fireblocking of chimneys and fireplaces, see Section 1003.19.
6. In buildings or structures with more than one dwelling unit, fireblocking of cornices is required at the line of dwelling unit separation.

302.11.1 Fireblocking materials. Except as provided in Section 302.11, Item 4, fireblocking shall consist of the following materials.

1. Two-inch (51 mm) nominal lumber
2. Two thicknesses of 1-inch (25.4 mm) nominal lumber with broken lap joints.
3. One thickness of $2\frac{3}{32}$ -inch (18.3 mm) wood structural panels with joints backed by $2\frac{3}{32}$ -inch (18.3 mm) wood structural panels.
4. One thickness of $\frac{3}{4}$ -inch (19.1 mm) particleboard with joints backed by $\frac{3}{4}$ -inch (19.1 mm) particleboard
5. One-half-inch (12.7 mm) gypsum board.
6. One-quarter-inch (6.4 mm) cement-based millboard.
7. Batts or blankets of mineral wool or glass fiber or other approved materials installed in such a manner as to be securely retained in place.
8. Cellulose insulation installed as tested in accordance with ASTM E119 or UL 263, for the specific application.

302.11.1.1 Batts or blankets of mineral or glass fiber. Batts or blankets of mineral or glass fiber or other approved nonrigid materials shall be permitted for compliance with the 10-foot (3048 mm) horizontal fireblocking in walls constructed using parallel rows of studs or staggered studs.

302.11.1.2 Unfaced fiberglass. Unfaced fiberglass batt insulation used as fireblocking shall fill the entire cross section of the wall cavity to a height of not less than 16 inches (406 mm) measured vertically. Where piping, conduit or similar obstructions are encountered, the insulation shall be packed tightly around the obstruction.

302.11.1.3 Loose-fill insulation material. Loose-fill insulation material shall not be used as a fireblock unless specifically tested in the form and manner intended for use to demonstrate its ability to remain in place and to retard the spread of fire and hot gases.

302.11.2 Fireblocking integrity. The integrity of fire-blocks shall be

maintained.

302.12 Draftstopping. In combustible construction where there is usable space both above and below the concealed space of a floor-ceiling assembly, draftstops shall be installed so that the area of the concealed space does not exceed 1,000 square feet (92.9 m²). Draftstopping shall divide the concealed space into approximately equal areas. Where the assembly is enclosed by a floor membrane above and a ceiling membrane below, draftstopping shall be provided in floor-ceiling assemblies under the following circumstances:

1. Ceiling is suspended under the floor framing.
2. Floor framing is constructed of truss-type open-web or perforated members.

302.12.1 Materials. Draftstopping materials shall be not less than 1/2 -inch (12.7 mm) gypsum board, 3/8 -inch (9.5 mm) wood structural panels or other approved materials adequately supported. Draftstopping shall be installed parallel to the floor framing members unless otherwise approved by the building official. The integrity of the draftstops shall be maintained.

302.13 Fire protection of floors. Floor assemblies that are not required elsewhere in this code to be fire-resistance rated, shall be provided with a 1/2 -inch (12.7 mm) gypsum board membrane, 5/8 -inch (16 mm) wood structural panel membrane, or equivalent material, which complies with section 302.15, on the underside of the floor framing member.

Exceptions:

1. Floor assemblies located directly over a space protected by an automatic sprinkler system in accordance with Section 2904, NFPA 13D, NFPA 13R or NFPA 13 as referenced in Chapter 44 of this code.
2. Floor assemblies located directly over an underfloor space as referenced in section 408 and not intended for storage or for the installation of fuel-fired or electric-powered heating appliances.
3. Portions of floor assemblies shall be permitted to be unprotected where complying with the following:
 - 3.1. The aggregate area of the unprotected portions shall not exceed 80 square feet (7.4 m²) per story.
 - 3.2. Fireblocking in accordance with Section 302.11.1 is installed along the perimeter of the unprotected portion to separate the unprotected portion from the remainder of the floor assembly.
4. Wood floor assemblies using dimension lumber or structural composite lumber equal to or greater than 2-inch by 10-inch (50.8 mm by 254 mm) nominal dimension, or other approved floor assemblies demonstrating equivalent fire performance.

302.14 Combustible insulation clearance. Combustible insulation shall be separated not less than 3 inches (76 mm) from recessed luminaires, fan motors and other heat-producing devices.

Exception: Where heat-producing devices are listed for lesser clearances, combustible insulation complying with the listing requirements shall be separated in accordance with the conditions stipulated in the listing.

Recessed luminaires installed in the building thermal envelope shall meet the requirements of Section 1102.4.5 of this code.

302.15 Fire resistance determination for assemblies and materials. When this chapter requires a fire resistive assembly or component, and there is no available evidence matching the assembly or component to a rated assembly or component tested in accordance with ASTM E 119 or UL 263, the fire resistance rating of the assembly or component can be evaluated by using section 721 in the “Ohio Building Code” or “Resource A, Guidelines on Fire Ratings of Archaic Materials and Assemblies in the International Existing Buildings Code.”

When this code requires an assembly or component to serve in a fire resistive manner but the assembly or component is not required to be fire resistance rated, equivalent fire resistive values can be derived from section 721 in the “Ohio Building Code” or “Resource A, Guidelines on Fire Ratings of Archaic Materials and Assemblies in the International Existing Building Code.”

SECTION 303 **LIGHT, VENTILATION AND HEATING**

303.1 Habitable rooms. Habitable rooms shall have an aggregate glazing area of not less than 8 percent of the floor area of such rooms. Natural ventilation shall be through windows, skylights, doors, louvers or other approved openings to the outdoor air. Such openings shall be provided with ready access or shall otherwise be readily controllable by the building occupants. The openable area to the outdoors shall be not less than 4 percent of the floor area being ventilated.

Exceptions:

1. The glazed areas need not be openable where the opening is not required by Section 310 and a whole-house mechanical ventilation system is installed in accordance with Section 1505.
2. The glazed areas need not be installed in rooms where exception 1 is satisfied and artificial light is provided that is capable of producing an

average illumination of 6 footcandles (65 lux) over the area of the room at a height of 30 inches (762 mm) above the floor level.

3. Use of sunroom and patio covers, as defined in Section 202, shall be permitted for natural ventilation if in excess of 40 percent of the exterior sunroom walls are open, or are enclosed only by insect screening.

303.2 Adjoining rooms. For the purpose of determining light and ventilation requirements, rooms shall be considered to be a portion of an adjoining room where not less than one-half of the area of the common wall is open and unobstructed and provides an opening of not less than one-tenth of the floor area of the interior room and not less than 25 square feet (2.3 m²).

Exception: Openings required for light or ventilation shall be permitted to open into a sunroom with thermal isolation or a patio cover, provided that there is an openable area between the adjoining room and the sunroom or patio cover of not less than one-tenth of the floor area of the interior room and not less than 20 square feet (2 m²). The minimum openable area to the outdoors shall be based on the total floor area being ventilated.

303.3 Bathrooms. Bathrooms, water closet compartments and other similar rooms shall be provided with aggregate glazing area in windows of not less than 3 square feet (0.3 m²), one-half of which shall be openable.

Exception: The glazed areas shall not be required where artificial light and a local exhaust system are provided. The minimum local exhaust rates shall be determined in accordance with Section 1505. Exhaust air from the space shall be exhausted directly to the outdoors.

303.4 Mechanical ventilation. Where the air infiltration rate of a dwelling unit is 5 air changes per hour or less where tested with a blower door at a pressure of 0.2 inch w.c. (50 Pa) in accordance with Section 1102.4.1.2 or Section 1112.2.4.2.1, the dwelling unit shall be provided with whole-house mechanical ventilation in accordance with Section 1505.4.

303.5 Opening location. Outdoor intake and exhaust openings shall be located in accordance with Sections 303.5.1 and 303.5.2.

303.5.1 Intake openings. Mechanical and gravity outdoor air intake openings shall be located not less than 10 feet (3048 mm) from any hazardous or noxious contaminant, such as vents, chimneys, plumbing vents, streets, alleys, parking lots and loading docks.

For the purpose of this section, the exhaust from dwelling unit toilet rooms, bathrooms and kitchens shall not be considered as hazardous or noxious.

Exceptions:

1. The 10-foot (3048 mm) separation is not required where the intake opening is located 3 feet (914 mm) or greater below the contaminant source.
2. Vents and chimneys serving fuel-burning appliances shall be terminated in accordance with the applicable provisions of Chapters 18 and 24.
3. Clothes dryer exhaust ducts shall be terminated in accordance with Section 1502.3.

303.5.2 Exhaust openings. Exhaust air shall not be directed onto walkways.

303.6 Outside opening protection. Air exhaust and intake openings that terminate outdoors shall be protected with corrosion-resistant screens, louvers or grilles having an opening size of not less than $\frac{1}{4}$ -inch (6 mm) and a maximum opening size of $\frac{1}{2}$ -inch (13 mm), in any dimension. Openings shall be protected against local weather conditions. Outdoor air, exhaust and intake openings shall meet the provisions for exterior wall opening protectives in accordance with this code.

303.7 Interior stairway illumination. Interior stairways shall be provided with an artificial light source to illuminate the landings and treads. The light source shall be capable of illuminating treads and landings to levels of not less than 1 foot-candle (11 lux) as measured at the center of treads and landings. There shall be a wall switch at each floor level to control the light source where the stairway has six or more risers.

Exception: A switch is not required where remote, central or automatic control of lighting is provided.

303.8 Exterior stairway illumination. Exterior stairways shall be provided with an artificial light source located at the top landing of the stairway. Exterior stairways providing access to a basement from the outdoor grade level shall be provided with an artificial light source located at the bottom landing of the stairway.

303.9 Required glazed openings. Required glazed openings shall open directly onto a street or public alley, or a yard or court located on the same lot as the building.

Exceptions:

1. Required glazed openings that face into a roofed porch where the porch abuts a street, yard or court and the longer side of the porch is not less than 65 percent unobstructed and the ceiling height is not less than 7 feet (2134 mm).
2. Eave projections shall not be considered as obstructing the clear open space

- of a yard or court.
3. Required glazed openings that face into the area under a deck, balcony, bay or floor cantilever where a clear vertical space not less than 36 inches (914 mm) in height is provided.

303.9.1 Sunroom additions. Required glazed openings shall be permitted to open into sunroom additions or patio covers that abut a street, yard or court if in excess of 40 percent of the exterior sunroom walls are open, or are enclosed only by insect screening, and the ceiling height of the sunroom is not less than 7 feet (2134 mm).

303.10 Required heating. Where the winter design temperature in Table 301.2(1) is below 60°F (16°C), every dwelling unit shall be provided with heating facilities capable of maintaining a room temperature of not less than 68°F (20°C) at a point 3 feet (914 mm) above the floor and 2 feet (610 mm) from exterior walls in habitable rooms at the design temperature. The installation of one or more portable space heaters shall not be used to achieve compliance with this section.

SECTION 304 **MINIMUM ROOM AREAS**

304.1 Minimum area. Habitable rooms shall have a floor area of not less than 70 square feet (6.5 m²).

Exception: Kitchens.

304.2 Minimum dimensions. Habitable rooms shall be not less than 7 feet (2134 mm) in any horizontal dimension.

Exception: Kitchens.

304.3 Height effect on room area. Portions of a room with a sloping ceiling measuring less than 5 feet (1524 mm) or a furred ceiling measuring less than 7 feet (2134 mm) from the finished floor to the finished ceiling shall not be considered as contributing to the minimum required habitable area for that room.

SECTION 305 **CEILING HEIGHT**

305.1 Minimum height. Habitable space, hallways and portions of basements containing these spaces shall have a ceiling height of not less than 7 feet (2134 mm). Bathrooms, toilet rooms and laundry rooms shall have a ceiling height of not less than 6 feet 8 inches (2032 mm).

Exceptions:

1. For rooms with sloped ceilings, the required floor area of the room shall have a ceiling height of not less than 5 feet (1524 mm) and not less than 50 percent of the required floor area shall have a ceiling height of not less than 7 feet (2134 mm).
2. The ceiling height above bathroom and toilet room fixtures shall be such that the fixture is capable of being used for its intended purpose. A shower or tub equipped with a showerhead shall have a ceiling height of not less than 6 feet 8 inches (2032 mm) above an area of not less than 30 inches (762 mm) by 30 inches (762 mm) at the showerhead.
3. Beams, girders, ducts or other obstructions in basements containing habitable space shall be permitted to project to within 6 feet 4 inches (1931 mm) of the finished floor.

305.1.1 Basements. P ortions of basements that do not contain habitable space or hallways shall have a ceiling height of not less than 6 feet 8 inches (2032 mm).

Exceptions:

1. At beams, girders, ducts or other obstructions, the ceiling height shall be not less than 6 feet 4 inches (1931 mm) from the finished floor.
2. *Habitable spaces created in existing basements shall be permitted to have ceiling heights of not less than 6 feet 8 inches (2032 mm). Obstructions may project to within 6 feet 4 inches of the basement floor.*

SECTION 306
SANITATION

306.1 Toilet facilities. Every dwelling unit shall be provided with a water closet, lavatory, and a bathtub or shower.

306.2 Kitchen. Each dwelling unit shall be provided with a kitchen area and every kitchen area shall be provided with a sink.

306.3 Sewage disposal. Plumbing fixtures shall be connected to a sanitary sewer or to an approved private sewage disposal system.

306.4 Water supply to fixtures. Plumbing fixtures shall be connected to an approved water supply. Kitchen sinks, lavatories, bathtubs, showers, bidets, laundry tubs and washing machine outlets shall be provided with hot and cold water.

SECTION 307
TOILET, BATH AND SHOWER SPACES

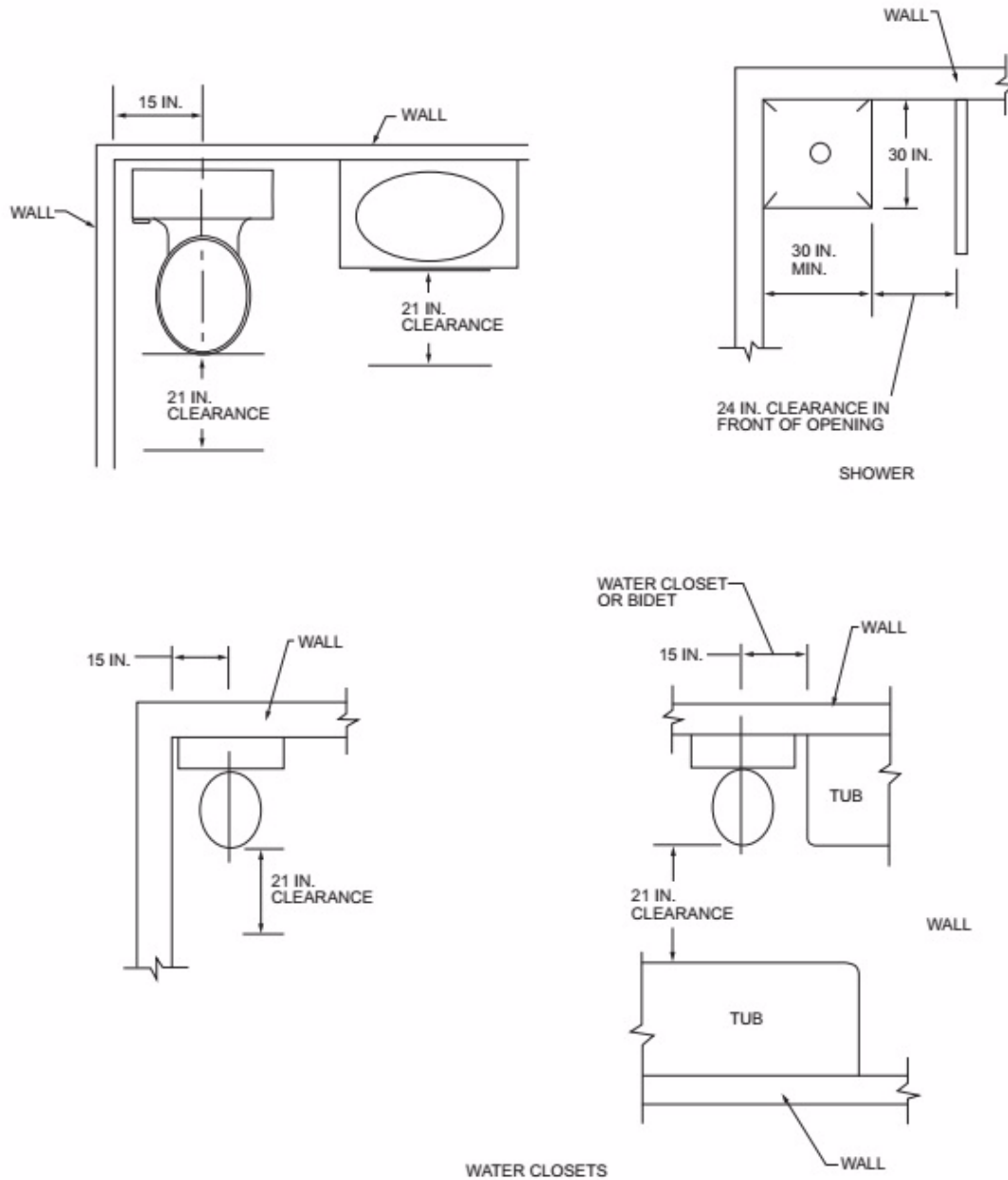

For SI: 1 inch = 25.4 mm.

FIGURE 307.1
MINIMUM FIXTURE CLEARANCES

307.1 Space required. Fixtures shall be spaced in accordance with Figure 307.1, and in accordance with the requirements of *the plumbing code*.

307.2 Bathtub and shower spaces. Bathtub and shower floors and walls above bathtubs with installed shower heads and in shower compartments shall be finished with a nonabsorbent surface. Such wall surfaces shall extend to a height of not less than 6 feet (1829 mm) above the floor.

SECTION 308 **GLAZING**

308.1 Identification. Except as indicated in Section 308.1.1 each pane of glazing installed in hazardous locations as defined in Section 308.4 shall be provided with a manufacturer's designation specifying who applied the designation, the type of glass and the safety glazing standard with which it complies, and that is visible in the final installation. The designation shall be acid etched, sandblasted, ceramic-fired, laser etched, embossed, or be of a type that once applied cannot be removed without being destroyed. A label shall be permitted in lieu of the manufacturer's designation.

Exceptions:

1. For other than tempered glass, manufacturer's designations are not required provided that the building official approves the use of a certificate, affidavit or other evidence confirming compliance with this code.
2. Tempered spandrel glass is permitted to be identified by the manufacturer with a removable paper designation.

308.1.1 Identification of multiple assemblies. Multi-pane assemblies having individual panes not exceeding 1 square foot (0.09 m²) in exposed area shall have not less than one pane in the assembly identified in accordance with Section 308.1. Other panes in the assembly shall be labeled "CPSC 16 CFR 1201" or "ANSI Z97.1" as appropriate.

308.2 Louvered windows or jalousies. Regular, float, wired or patterned glass in jalousies and louvered windows shall be not less than nominal ³/₁₆ -inch (5 mm) thick and not more than 48 inches (1219 mm) in length. Exposed glass edges shall be smooth.

308.2.1 Wired glass prohibited. Wired glass with wire exposed on longitudinal edges shall not be used in jalousies or louvered windows.

308.3 Human impact loads. Individual glazed areas, including glass mirrors in hazardous locations such as those indicated as defined in Section 308.4, shall pass the test requirements of Section 308.3.1.

Exceptions:

1. Louvered windows and jalousies shall comply with Section 308.2.
2. Mirrors and other glass panels mounted or hung on a surface that provides a continuous backing support.
3. Glass unit masonry complying with Section 607.

308.3.1 Impact test. Where required by other sections of the code, glazing shall be tested in accordance with CPSC 16 CFR 1201. Glazing shall comply with the test criteria for Category II unless otherwise indicated in Table 308.3.1(1).

Exception: Glazing not in doors or enclosures for hot tubs, whirlpools, saunas, steam rooms, bathtubs and showers shall be permitted to be tested in accordance with ANSI Z97.1. Glazing shall comply with the test criteria for Class A unless otherwise indicated in Table 308.3.1(2).

**TABLE 308.3.1(1)
MINIMUM CATEGORY CLASSIFICATION OF GLAZING USING CPSC 16 CFR 1201**

<u>EXPOSED SURFACE AREA OF ONE SIDE OF ONE LITE</u>	<u>GLAZING IN STORM OR COMBINATION DOORS (Category Class)</u>	<u>GLAZING IN DOORS (Category Class)</u>	<u>GLAZED PANELS REGULATED BY SECTION 308.4.3 (Category Class)</u>	<u>GLAZED PANELS REGULATED BY SECTION 308.4.2 (Category Class)</u>	<u>GLAZING IN DOORS AND ENCLOSURES REGULATED BY SECTION 308.4.5 (Category Class)</u>	<u>SLIDING GLASS DOORS PATIO TYPE (Category Class)</u>
9 square feet or less	I	I	NR	I	II	II
More than 9 square feet	II	II	II	II	II	II

For SI: 1 square foot = 0.0929 m². NR = No Requirement.

**TABLE 308.3.1(2)
MINIMUM CATEGORY CLASSIFICATION OF GLAZING USING ANSI Z97.1**

<u>EXPOSED SURFACE AREA OF ONE SIDE OF ONE LITE</u>	<u>GLAZED PANELS REGULATED BY SECTION 308.4.3 (Category Class)</u>	<u>GLAZED PANELS REGULATED BY SECTION 308.4.2 (Category Class)</u>	<u>DOORS AND ENCLOSURES REGULATED BY SECTION 308.4.5^a (Category Class)</u>
9 square feet or less	No requirement	B	A
More than 9 square feet	A	A	A

For SI: 1 square foot = 0.0929 m².

a. Use is permitted only by the exception to Section 308.3.1.

308.4 Hazardous locations. The locations specified in Sections 308.4.1 through 308.4.7 shall be considered to be specific hazardous locations for the purposes of glazing.

308.4.1 Glazing in doors. Glazing in fixed and operable panels of swinging,

sliding and bifold doors shall be considered to be a hazardous location.

Exceptions:

1. Glazed openings of a size through which a 3 -inch-diameter (76 mm) sphere is unable to pass.
2. Decorative glazing.

308.4.2 Glazing adjacent to doors. Glazing in an individual fixed or operable panel adjacent to a door shall be considered to be a hazardous location where the bottom exposed edge of the glazing is less than 60 inches (1524 mm) above the floor or walking surface and it meets either of the following conditions:

1. Where the glazing is within 24 inches (610 mm) of either side of the door in the plane of the door in a closed position.
2. Where the glazing is on a wall less than 180 degrees (3.14 rad) from the plane of the door in a closed position and within 24 inches (610 mm) of the hinge side of an in-swinging door.

Exceptions:

1. Decorative glazing.
2. Where there is an intervening wall or other permanent barrier between the door and the glazing.
3. Where access through the door is to a closet or storage area 3 feet (914 mm) or less in depth. Glazing in this application shall comply with Section 308.4.3.
4. Glazing that is adjacent to the fixed panel of patio doors.

308.4.3 Glazing in windows. Glazing in an individual fixed or operable panel that meets all of the following conditions shall be considered to be a hazardous location:

1. The exposed area of an individual pane is larger than 9 square feet (0.836 m²).
2. The bottom edge of the glazing is less than 18 inches (457 mm) above the floor.
3. The top edge of the glazing is more than 36 inches (914 mm) above the floor.
4. One or more walking surfaces are within 36 inches (914 mm), measured horizontally and in a straight line, of the glazing.

Exceptions:

1. Decorative glazing.
2. Where glazing is adjacent to a walking surface and a horizontal rail is installed 34 to 38 inches (864 to 965 mm) above the walking surface. The rail shall be capable of withstanding a horizontal

load of 50 pounds per linear foot (730 N/m) without contacting the glass and have a cross-sectional height of not less than 1¹/₂ inches (38 mm).

3. Outboard panes in insulating glass units and other multiple glazed panels where the bottom edge of the glass is 25 feet (7620 mm) or more above grade, a roof, walking surfaces or other horizontal [within 45degrees (0.79 rad) of horizontal] surface adjacent to the glass exterior.

308.4.4 Glazing in guards and railings. Glazing in guards and railings, including structural baluster panels and nonstructural in-fill panels, regardless of area or height above a walking surface shall be considered to be a hazardous location.

308.4.4.1 Structural glass baluster panels. Guards with structural glass baluster panels shall be installed with an attached top rail or handrail. The top rail or handrail shall be supported by not less than three glass baluster panels, or shall be otherwise supported to remain in place should one glass baluster panel fail.

Exception: An attached top rail or handrail is not required where the glass baluster panels are laminated glass with two or more glass plies of equal thickness and of the same glass type.

308.4.5 Glazing and wet surfaces. Glazing in walls, enclosures or fences containing or facing hot tubs, spas, whirlpools, saunas, steam rooms, bathtubs, showers and indoor or outdoor swimming pools where the bottom exposed edge of the glazing is less than 60 inches (1524 mm) measured vertically above any standing or walking surface shall be considered to be a hazardous location. This shall apply to single glazing and each pane in multiple glazing.

Exception: Glazing that is more than 60 inches (1524 mm), measured horizontally and in a straight line, from the water's edge of a bathtub, hot tub, spa, whirlpool or swimming pool or from the edge of a shower, sauna or steam room.

308.4.6 Glazing adjacent to stairs and ramps. Glazing where the bottom exposed edge of the glazing is less than 36 inches (914 mm) above the plane of the adjacent walking surface of stairways, landings between flights of stairs and ramps shall be considered to be a hazardous location.

Exceptions:

1. Where glazing is adjacent to a walking surface and a horizontal rail is installed at 34 to 38 inches (864 to 965 mm) above the walking surface.

The rail shall be capable of withstanding a horizontal load of 50 pounds per linear foot (730 N/m) without contacting the glass and have a cross-sectional height of not less than 1½ inches (38 mm).

2. Glazing 36 inches (914 mm) or more measured horizontally from the walking surface.

308.4.7 Glazing adjacent to the bottom stair landing. Glazing adjacent to the landing at the bottom of a stairway where the glazing is less than 36 inches (914 mm) above the landing and within a 60-inch (1524 mm) horizontal arc less than 180 degrees (3.14 rad) from the bottom tread nosing shall be considered to be a hazardous location.

Exception: Where the glazing is protected by a guard complying with Section 312 and the plane of the glass is more than 18 inches (457 mm) from the guard.

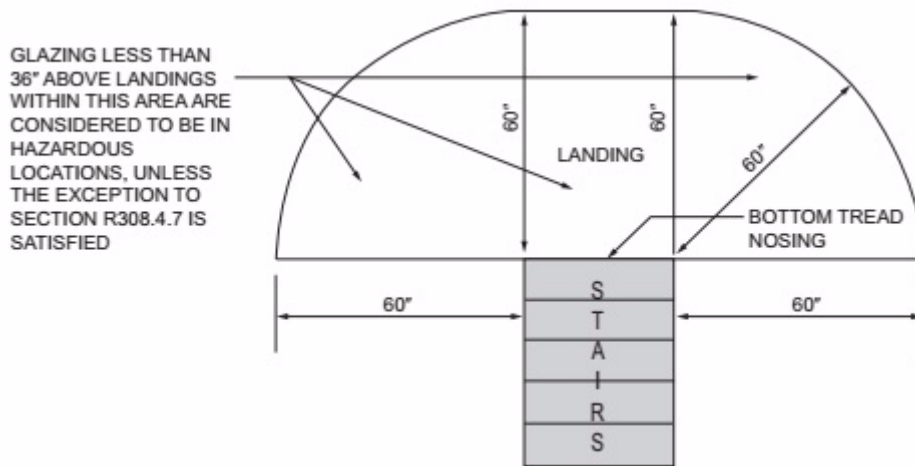

For SI: 1 inch = 25.4 mm.

FIGURE 308.4.7
HAZARDOUS GLAZING LOCATIONS AT BOTTOM STAIR LANDINGS

308.5 Site-built fenestration products. Site-built fenestration products shall comply with Section 2404 of the Ohio building code.

308.6 Skylights and sloped glazing. Skylights and sloped glazing shall comply with the following sections.

308.6.1 Definitions. The following terms are defined in Chapter 2:

SKYLIGHT, UNIT.

SKYLIGHTS AND SLOPED GLAZING.

TUBULAR DAYLIGHTING DEVICE (TDD).

308.6.2 Materials. Glazing materials shall be limited to the following:

1. Laminated glass with not less than a 0.015-inch (0.38 mm) polyvinyl butyral interlayer for glass panes 16 square feet (1.5 m²) or less in area located such that the highest point of the glass is not more than 12 feet (3658 mm) above a walking surface; for higher or larger sizes, the interlayer thickness shall be not less than 0.030 inch (0.76 mm).
2. Fully tempered glass.
3. Heat-strengthened glass.
4. Wired glass.
5. Approved rigid plastics.

308.6.3 Screens, general. For fully tempered or heat-strengthened glass, a retaining screen meeting the requirements of Section 308.6.7 shall be installed below the glass, except for fully tempered glass that meets either condition listed in Section 308.6.5.

308.6.4 Screens with multiple glazing. Where the inboard pane is fully tempered, heat-strengthened or wired glass, a retaining screen meeting the requirements of Section 308.6.7 shall be installed below the glass, except for either condition listed in Section 308.6.5. Other panes in the multiple glazing shall be of any type listed in Section 308.6.2.

308.6.5 Screens not required. Screens shall not be required where fully tempered glass is used as single glazing or the inboard pane in multiple glazing and either of the following conditions are met:

1. The glass area is 16 square feet (1.49 m²) or less; the highest point of glass is not more than 12 feet (3658 mm) above a walking surface; the nominal glass thickness is not more than ³/₁₆ inch (4.8 mm); and (for multiple glazing only) the other pane or panes are fully tempered, laminated or wired glass.
2. The glass area is greater than 16 square feet (1.49 m²); the glass is sloped 30 degrees (0.52 rad) or less from vertical; and the highest point of glass is not more than 10 feet (3048 mm) above a walking surface.

308.6.6 Glass in greenhouses. Any glazing material is permitted to be installed without screening in the sloped areas of greenhouses, provided that the greenhouse height at the ridge does not exceed 20 feet (6096 mm) above grade.

308.6.7 Screen characteristics. The screen and its fastenings shall be capable of supporting twice the weight of the glazing, be firmly and substantially fastened to the framing members, and have a mesh opening of not more than 1 inch by 1 inch (25 mm by 25 mm).

308.6.8 Curbs for skylights. Unit skylights installed in a roof with a pitch of less than three units vertical in 12 units horizontal (25-percent slope) shall be mounted on a curb extending not less than 4 inches (102 mm) above the plane of the roof, unless otherwise specified in the manufacturer's installation instructions.

308.6.9 Testing and labeling. Unit skylights and tubular daylighting devices shall be tested by an approved independent laboratory, and bear a label identifying manufacturer, performance grade rating and approved inspection agency to indicate compliance with the requirements of AAMA/WDMA/CSA 101/I.S.2/A440.

308.6.9.1 Comparative analysis for glass-glazed unit skylights. Structural wind load design pressures for glass-glazed unit skylights different than the size tested in accordance with Section 308.6.9 shall be permitted to be different than the design value of the tested unit where determined in accordance with one of the following comparative analysis methods:

1. Structural wind load design pressures for glass-glazed unit skylights smaller than the size tested in accordance with Section 308.6.9 shall be permitted to be higher than the design value of the tested unit provided that such higher pressures are determined by accepted engineering analysis. Components of the smaller unit shall be the same as those of the tested unit. Such calculated design pressures shall be validated by an additional test of the glass-glazed unit skylight having the highest allowable design pressure.
2. In accordance with WDMA I.S. 11.

SECTION 309 **GARAGES AND CARPORTS**

309.1 Floor surface. Garage floor surfaces shall be of approved noncombustible material.

The area of floor used for parking of automobiles or other vehicles shall be sloped to facilitate the movement of liquids to a drain or toward the main vehicle entry doorway.

309.2 Carports. Carports shall be open on not less than two sides. Carport floor surfaces shall be of approved noncombustible material. Carports not open on two or more sides shall be considered to be a garage and shall comply with the provisions of this section for garages.

The area of floor used for parking of automobiles or other vehicles shall be sloped to facilitate the movement of liquids to a drain or toward the main vehicle entry doorway.

Exception: Asphalt surfaces shall be permitted at ground level in carports.

309.3 Flood hazard areas. For buildings located in flood hazard areas as established by Table 301.2(1), garage floors shall be one of the following:

1. Elevated to or above the design flood elevation as determined in accordance with Section 322.
2. Located below the design flood elevation provided that the floors are at or above grade on not less than one side, are used solely for parking, building access or storage, meet the requirements of Section 322 and are otherwise constructed in accordance with this code.

309.4 Automatic garage door openers. Automatic garage door openers, if provided, shall be listed and labeled in accordance with UL 325.

309.5 Fire sprinklers. Private garages shall be protected by fire sprinklers where the garage wall has been designed based on Table 302.1(2), Note a. Sprinklers in garages shall be connected to an automatic sprinkler system that complies with Section 2904. Garage sprinklers shall be residential sprinklers or quick-response sprinklers, designed to provide a density of 0.05 gpm/ft². Garage doors shall not be considered obstructions with respect to sprinkler placement.

SECTION 310 **EMERGENCY ESCAPE AND RESCUE OPENINGS**

310.1 Emergency escape and rescue opening required. *Every* sleeping room shall have not less than one operable emergency escape and rescue opening. Emergency escape and rescue openings shall open directly into a public way, or to a yard or court that opens to a public way.

Exceptions: Where the dwelling *or dwelling unit* is equipped with an automatic sprinkler system installed in accordance with Section 2904, sleeping rooms in basements shall not be required to have emergency escape and rescue openings provided that the basement has one of the following:

1. One means of egress complying with Section 311 and one emergency escape and rescue opening.
2. Two means of egress complying with Section 311.

310.1.1 Operational constraints and opening control devices. Emergency escape and rescue openings shall be operational from the inside of the room without the use of keys, tools or special knowledge. Window opening control devices on windows serving as a required emergency escape and rescue opening shall comply with ASTM F2090.

310.2 Emergency escape and rescue openings. Emergency escape and rescue openings shall have minimum dimensions as specified in this section.

310.2.1 Minimum opening area. Emergency and escape rescue openings shall have a net clear opening of not less than 5.7 square feet (0.530 m²). The net clear opening dimensions required by this section shall be obtained by the normal operation of the emergency escape and rescue opening from the inside. The net clear height of the opening shall be not less than 24 inches (610 mm) and the net clear width shall be not less than 20 inches (508 mm).

Exception: Grade floor openings or below-grade openings shall have a net clear opening area of not less than 5 square feet (0.465 m²).

310.2.2 Window sill height. Where a window is provided as the emergency escape and rescue opening, it shall have a sill height of not more than 44 inches (1118 mm) above the floor; where the sill height is below grade, it shall be provided with a window well in accordance with Section 310.2.3.

310.2.3 Window wells. The horizontal area of the window well shall be not less than 9 square feet (0.9 m²), with a horizontal projection and width of not less than 36 inches (914 mm). The area of the window well shall allow the emergency escape and rescue opening to be fully opened.

Exception: The ladder or steps required by Section 310.2.3.1 shall be permitted to encroach not more than 6 inches (152 mm) into the required dimensions of the window well.

310.2.3.1 Ladder and steps. Window wells with a vertical depth greater than 44 inches (1118 mm) shall be equipped with a permanently affixed ladder or steps usable with the window in the fully open position. Ladders or steps required by this section shall not be required to comply with Section 311.7. Ladders or rungs shall have an inside width of not less than 12 inches (305 mm), shall project not less than 3 inches (76 mm) from the wall and

shall be spaced not more than 18 inches (457 mm) on center vertically for the full height of the window well.

310.2.3.2 Drainage. Window wells shall be designed for proper drainage by connecting to the building's foundation drainage system required by Section 405.1 or by an approved alternative method.

Exception: A drainage system for window wells is not required where the foundation is on well-drained soil or sand-gravel mixture soils in accordance with the United Soil Classification System, Group I Soils, as detailed in Table 405.1.

310.2.4 Emergency escape and rescue openings under decks and porches. Emergency escape and rescue openings installed under decks and porches shall be fully openable and provide a path not less than 36 inches (914 mm) in height to a yard or court.

310.2.5 Replacement windows. Replacement windows installed in buildings meeting the scope of this code shall be exempt from the maximum sill height requirements of Section 310.2.2 and the requirements of Section 310.2.1, provided that the replacement window meets the following conditions:

1. The replacement window is the manufacturer's largest standard size window that will fit within the existing frame or existing rough opening. The replacement window is of the same operating style as the existing window or a style that provides for an equal or greater window opening area than the existing window.
2. The replacement window is not part of a change of occupancy.

Exception: Replacement windows installed in accordance with Section 113.5.1 shall not be required to comply with 310.2.1

310.3 Emergency escape and rescue doors. Where a door is provided as the required emergency escape and rescue opening, it shall be a side-hinged door or a slider. Where the opening is below the adjacent grade, it shall be provided with an area well.

310.3.1 Minimum door opening size. The minimum net clear height opening for any door that serves as an emergency and escape rescue opening shall be in accordance with Section 310.2.1.

310.3.2 Area wells. Area wells shall have a width of not less than 36 inches (914 mm). The area well shall be sized to allow the emergency escape and rescue door to be fully opened.

310.3.2.1 Ladder and steps. Area wells with a vertical depth greater than 44 inches (1118 mm) shall be equipped with a permanently affixed ladder or steps usable with the door in the fully open position. Ladders or steps required by this section shall not be required to comply with Section 311.7. Ladders or rungs shall have an inside width of not less than 12 inches (305 mm), shall project not less than 3 inches (76 mm) from the wall and shall be spaced not more than 18 inches (457 mm) on center vertically for the full height of the exterior stairwell.

310.3.2.2 Drainage. Area wells shall be designed for proper drainage by connecting to the building's foundation drainage system required by Section 405.1 or by an approved alternative method.

Exception: A drainage system for area wells is not required where the foundation is on well-drained soil or sand-gravel mixture soils in accordance with the United Soil Classification System, Group I Soils, as detailed in Table 405.1.

310.4 Bars, grilles, covers and screens. Where bars, grilles, covers, screens or similar devices are placed over emergency escape and rescue openings, area wells, or window wells, the minimum net clear opening size shall comply with Sections 310.2.1 through 310.2.3, and such devices shall be releasable or removable from the inside without the use of a key, tool, special knowledge or force greater than that required for the normal operation of the escape and rescue opening.

310.5 Dwelling additions. Where dwelling additions contain sleeping rooms, an emergency escape and rescue opening shall be provided in each new sleeping room.

310.6 Alterations or repairs of existing basements. An emergency escape and rescue opening is not required where existing basements undergo alterations or repairs.

Exception: New sleeping rooms created in an existing basement shall be provided with emergency escape and rescue openings in accordance with Section 310.1.

SECTION 311 **MEANS OF EGRESS**

311.1 Means of egress. Dwellings shall be provided with a means of egress in accordance with this section. The means of egress shall provide a continuous and unobstructed path of vertical and horizontal egress travel from all portions of the

dwelling to the required egress door without requiring travel through a garage. The required egress door shall open directly into a public way or to a yard or court that opens to a public way.

311.2 Egress door. Not less than one egress door shall be provided for each dwelling unit. The egress door shall be side-hinged, and shall provide a clear width of not less than 32 inches (813 mm) where measured between the face of the door and the stop, with the door open 90 degrees (1.57 rad). The clear height of the door opening shall be not less than 78 inches (1981 mm) in height measured from the top of the threshold to the bottom of the stop. Other doors shall not be required to comply with these minimum dimensions. Egress doors shall be readily openable from inside the dwelling without the use of a key or special knowledge or effort.

311.2.1 Garage access doors. Garages shall be served by at least one side-hinged door not less than 2 feet 6 inches (760 mm) in width and 6 feet 8 inches (2032 mm) in height. Such door located between a dwelling and an attached garage shall be acceptable for meeting this requirement.

311.3 Floors and landings at exterior doors. There shall be a landing or floor on each side of each exterior door. The width of each landing shall be not less than the door served. Landings shall have a dimension of not less than 36 inches (914 mm) measured in the direction of travel. The slope at exterior landings shall not exceed $\frac{1}{4}$ unit vertical in 12 units horizontal (2 percent).

Exception: Exterior balconies less than 60 square feet (5.6 m²) and only accessed from a door are permitted to have a landing that is less than 36 inches (914 mm) measured in the direction of travel.

311.3.1 Floor elevations at the required egress doors. Landings or finished floors at the required egress door shall be not more than 1 $\frac{1}{2}$ inches (38 mm) lower than the top of the threshold.

Exception: The landing or floor on the exterior side shall be not more than 8 $\frac{1}{4}$ -inches (209 mm) below the top of the threshold provided that the door does not swing over the landing or floor.

Where exterior landings or floors serving the required egress door are not at grade, they shall be provided with access to grade by means of a ramp in accordance with Section 311.8 or a stairway in accordance with Section 311.7.

311.3.2 Floor elevations at other exterior doors. Doors other than the required egress door shall be provided with landings or floors not more than 8 $\frac{1}{4}$ -inches (209 mm) below the top of the threshold.

Exception: A top landing is not required for the stairway located on the exterior side of the door, provided that the threshold of the door is not more than 30" above the adjacent grade and the door does not swing over the stairway.

311.3.3 Storm and screen doors. Storm and screen doors shall be permitted to swing over exterior stairs and landings.

311.4 Vertical egress. Egress from habitable levels including habitable attics and basements that are not provided with an egress door in accordance with Section 311.2 shall be by a ramp in accordance with Section 311.8 or a stairway in accordance with Section 311.7.

311.5 Landing, deck, balcony and stair construction and attachment. Exterior landings, decks, balconies, stairs and similar facilities shall be positively anchored to the primary structure to resist both vertical and lateral forces or shall be designed to be self-supporting. Attachment shall not be accomplished by use of toenails or nails subject to withdrawal.

311.6 Hallways. The width of a hallway shall be not less than 3 feet (914 mm).

311.7 Stairways.

311.7.1 Width. Stairways shall be not less than 36 inches (914 mm) in clear width at all points above the permitted handrail height and below the required headroom height. The clear width of stairways at and below the handrail height, including treads and landings, shall be not less than 31 1/2 inches (787 mm) where a handrail is installed on one side and 27 inches (698 mm) where handrails are installed on both sides.

Exception: The width of spiral stairways shall be in accordance with Section 311.7.10.1.

311.7.2 Headroom. The headroom in stairways shall be not less than 6 feet 8 inches (2032 mm) measured vertically from the sloped line adjoining the tread nosing or from the floor surface of the landing or platform on that portion of the stairway.

Exceptions:

- 1.** Where the nosings of treads at the side of a flight extend under the edge of a floor opening through which the stair passes, the floor opening shall not project horizontally into the required headroom more than 4 3/4 inches (121 mm).

2. The headroom for spiral stairways shall be in accordance with Section 311.7.10.1.

311.7.3 Vertical rise. A flight of stairs shall not have a vertical rise larger than $148\frac{1}{2}$ -inches (3772 mm) between floor levels or landings.

311.7.4 Walkline. The walkline across winder treads and landings shall be concentric to the turn and parallel to the direction of travel entering and exiting the turn. The walkline shall be located 12 inches (305 mm) from the inside of the turn. The 12-inch (305 mm) dimension shall be measured from the widest point of the clear stair width at the walking surface. Where winders are adjacent within a flight, the point of the widest clear stair width of the adjacent winders shall be used.

311.7.5 Stair treads and risers. Stair treads and risers shall meet the requirements of this section. For the purposes of this section, dimensions and dimensioned surfaces shall be exclusive of carpets, rugs or runners.

311.7.5.1 Risers. The riser height shall be not more than $8\frac{1}{4}$ -inches (209 mm). The riser shall be measured vertically between leading edges of the adjacent treads. The greatest riser height within any flight of stairs shall not exceed the smallest by more than $\frac{3}{8}$ inch (9.5 mm). Risers shall be vertical or sloped from the underside of the nosing of the tread above at an angle not more than 30 degrees (0.51 rad) from the vertical. At open risers, openings located more than 30 inches (762 mm), as measured vertically, to the floor or grade below shall not permit the passage of a 4-inch-diameter (102 mm) sphere.

Exceptions:

1. The opening between adjacent treads is not limited on spiral stairways.
2. The riser height of spiral stairways shall be in accordance with Section 311.7.10.1.

311.7.5.2 Treads. The tread depth shall be not less than 9 -inches (229 mm). The tread depth shall be measured horizontally between the vertical planes of the foremost projection of adjacent treads and at a right angle to the tread's leading edge. The greatest tread depth within any flight of stairs shall not exceed the smallest by more than $\frac{3}{8}$ inch (9.5 mm).

311.7.5.2.1 Winder treads. Winder treads shall have a tread depth of not less than 9 -inches (229 mm) measured between the vertical planes

of the foremost projection of adjacent treads at the intersections with the walkline. Winder treads shall have a tread depth of not less than 6 inches (152 mm) at any point within the clear width of the stair. Within any flight of stairs, the largest winder tread depth at the walkline shall not exceed the smallest winder tread by more than $\frac{3}{8}$ inch (9.5 mm). Consistently shaped winders at the walkline shall be allowed within the same flight of stairs as rectangular treads and shall not be required to be within $\frac{3}{8}$ inch (9.5 mm) of the rectangular tread depth.

Exception: The tread depth at spiral stairways shall be in accordance with Section 311.7.10.1.

311.7.5.3 Nosings. Nosings at treads, landings and floors of stairways shall have a radius of curvature at the nosing not greater than $\frac{9}{16}$ inch (14 mm) or a bevel not greater than $\frac{1}{2}$ inch (12.7 mm). A nosing projection not less than $\frac{3}{4}$ inch (19 mm) and not more than $1\frac{1}{4}$ inches (32 mm) shall be provided on stairways. The greatest nosing projection shall not exceed the smallest nosing projection by more than $\frac{3}{8}$ -inch (9.5 mm) within a stairway.

Exception: A nosing projection is not required where the tread depth is not less than 11 inches (279 mm).

311.7.5.4 Exterior plastic composite stair treads. Plastic composite exterior stair treads shall comply with the provisions of this section and Section 507.2.2.

311.7.6 Landings for stairways. There shall be a floor or landing at the top and bottom of each stairway. The width perpendicular to the direction of travel shall be not less than the width of the flight served. For landings of shapes other than square or rectangular, the depth at the walk line and the total area shall be not less than that of a quarter circle with a radius equal to the required landing width. Where the stairway has a straight run, the depth in the direction of travel shall be not less than 36 inches (914 mm).

Exception: A floor or landing is not required at the top of an interior flight of stairs, including stairs in an enclosed garage, provided that a door does not swing over the stairs.

311.7.7 Stairway walking surface. The walking surface of treads and landings of stairways shall be sloped not steeper than one unit vertical in 48 inches horizontal (2-percent slope).

311.7.8 Handrails. Handrails shall be provided on not less than one side of

each flight of stairs with four or more risers.

311.7.8.1 Height. Handrail height, measured vertically from the sloped plane adjoining the tread nosing, or finish surface of ramp slope, shall be not less than 34 inches (864 mm) and not more than 38 inches (965 mm)

Exceptions:

1. The use of a volute, turnout or starting easing shall be allowed over the lowest tread.
2. Where handrail fittings or bendings are used to provide continuous transition between flights, transitions at winder treads, the transition from handrail to guard, or used at the start of a flight, the handrail height at the fittings or bendings shall be permitted to exceed 38 inches (956 mm).

311.7.8.2 Handrail projection. Handrails shall not project more than 4¹/₂ inches (114 mm) on either side of the stairway.

Exception: Where nosings of landings, floors or passing flights project into the stairway reducing the clearance at passing handrails, handrails shall project not more than 6¹/₂ inches (165 mm) into the stairway, provided that the stair width and handrail clearance are not reduced to less than that required.

311.7.8.3 Handrail clearance. Handrails adjacent to a wall shall have a space of not less than 1¹/₂ inches (38 mm) between the wall and the handrails.

311.7.8.4 Continuity. Handrails shall be continuous for the full length of the flight, from a point directly above the top riser of the flight to a point directly above the lowest riser of the flight. Handrail ends shall be returned or shall terminate in newel posts or safety terminals.

Exceptions:

1. Handrail continuity shall be permitted to be interrupted by a newel post at a turn in a flight with winders, at a landing, or over the lowest tread.
2. A volute, turnout or starting easing shall be allowed to terminate over the lowest tread.
3. Two or more separate rails shall be considered continuous if the termination of the rails occurs over a single tread and positioned within 4 inches of each other. If the transition occurs between a wall mounted handrail and handrail/guardrail combination, the wall mounted handrail shall return into the wall.

311.7.8.5 Grip size. Required handrails shall be of one of the following types or provide equivalent graspability.

- 1. Type I.** Handrails with a circular cross section shall have an outside diameter of not less than $1\frac{1}{4}$ inches (32 mm) and not greater than 2 inches (51 mm). If the handrail is not circular, it shall have a perimeter of not less than 4 inches (102 mm) and not greater than $6\frac{1}{4}$ inches (160 mm) and a cross section of not more than $2\frac{1}{4}$ inches (57 mm). Edges shall have a radius of not less than 0.01 inch (0.25 mm).
- 2. Type II.** Handrails with a perimeter greater than $6\frac{1}{4}$ -inches (160 mm) shall have a graspable finger recess area on both sides of the profile. The finger recess shall begin within $\frac{3}{4}$ -inch (19 mm) measured vertically from the tallest portion of the profile and have a depth of not less than $\frac{5}{16}$ -inch (8 mm) within $\frac{7}{8}$ -inch (22 mm) below the widest portion of the profile. This required depth shall continue for not less than $\frac{3}{8}$ -inch (10 mm) to a level that is not less than $1\frac{3}{4}$ -inches (45 mm) below the tallest portion of the profile. The width of the handrail above the recess shall be not less than $1\frac{1}{4}$ -inches (32 mm) and not more than $2\frac{3}{4}$ -inches (70 mm). Edges shall have a radius of not less than 0.01 inch (0.25 mm).

311.7.8.6 Exterior plastic composite handrails. Plastic composite exterior handrails shall comply with the requirements of Section 507.2.2.

311.7.9 Illumination. Stairways shall be provided with illumination in accordance with Sections 303.7 and 303.8.

311.7.10 Special stairways. Spiral stairways and bulkhead enclosure stairways shall comply with the requirements of Section 311.7 except as specified in Sections 311.7.10.1 and 311.7.10.2.

311.7.10.1 Spiral stairways. The clear width at and below the handrails at spiral stairways shall be not less than 26 inches (660 mm) and the walkline radius shall be not greater than $24\frac{1}{2}$ inches (622 mm). Each tread shall have a depth of no less than $6\frac{3}{4}$ inches (171 mm) at the walkline. Treads shall be identical, and the rise shall be not more than $9\frac{1}{2}$ inches (241 mm). Headroom shall be not less than 6 feet 6 inches (1982 mm).

311.7.10.2 Bulkhead enclosure stairways. Stairways serving bulkhead enclosures, not part of the required building egress, providing access from

the outside grade level to the basement shall be exempt from the requirements of Sections 311.3 and 311.7 where the height from the basement finished floor level to grade adjacent to the stairway is not more than 8 feet (2438 mm) and the grade level opening to the stairway is covered by a bulkhead enclosure with hinged doors or other approved means.

311.7.11 Alternating tread devices. Alternating tread devices shall not be used as an element of a means of egress. Alternating tread devices shall be permitted provided that a required means of egress stairway or ramp serves the same space at each adjoining level or where a means of egress is not required. The clear width at and below the handrails shall be not less than 20 inches (508 mm).

Exception: Alternating tread devices are allowed to be used as an element of a means of egress for lofts, mezzanines and similar areas of 200 gross square feet (18.6m²) or less where such devices do not provide exclusive access to a kitchen or bathroom.

311.7.11.1 Treads of alternating tread devices. Alternating tread devices shall have a tread depth of not less than 5 inches (127 mm), a projected tread depth of not less than 8^{1/2} inches (216 mm), a tread width of not less than 7 inches (178 mm) and a riser height of not more than 9^{1/2} inches (241 mm). The tread depth shall be measured horizontally between the vertical planes of the foremost projections of adjacent treads. The riser height shall be measured vertically between the leading edges of adjacent treads. The riser height and tread depth provided shall result in an angle of ascent from the horizontal of between 50 and 70 degrees (0.87 and 1.22 rad). The initial tread of the device shall begin at the same elevation as the platform, landing or floor surface.

311.7.11.2 Handrails of alternating tread devices. Handrails shall be provided on both sides of alternating tread devices and shall comply with Sections 311.7.8.2 to 311.7.8.6. Handrail height shall be uniform, not less than 30 inches (762 mm) and not more than 34 inches (864 mm).

311.7.12 Ships ladders. Ships ladders shall not be used as an element of a means of egress. Ships ladders shall be permitted provided that a required means of egress stairway or ramp serves the same space at each adjoining level or where a means of egress is not required. The clear width at and below the handrails shall be not less than 20 inches (508 mm).

Exception: Ships ladders are allowed to be used as an element of a means of egress for lofts, mezzanines and similar areas of 200 gross square feet

(18.6 m²) or less that do not provide exclusive access to a kitchen or bathroom.

311.7.12.1 Treads of ships ladders. Treads shall have a depth of not less than 5 inches (127 mm). The tread shall be projected such that the total of the tread depth plus the nosing projection is not less than 8¹/₂ inches (216 mm). The riser height shall be not more than 9¹/₂ inches (241 mm).

311.7.12.2 Handrails of ships ladders. Handrails shall be provided on both sides of ships ladders and shall comply with Sections 311.7.8.2 to 311.7.8.6. Handrail height shall be uniform, not less than 30 inches (762 mm) and not more than 34 inches (864 mm).

311.8 Ramps.

311.8.1 Maximum slope. Ramps serving the egress door required by Section 311.2 shall have a slope of not more than 1 unit vertical in 8 units horizontal (12.5 -percent slope).

311.8.2 Landings required. There shall be a floor or landing at the top and bottom of each ramp, where doors open onto ramps, and where ramps change directions. The width of the landing perpendicular to the ramp slope shall be not less than 36 inches (914 mm).

311.8.3 Handrails required. Handrails shall be provided on not less than one side of ramps exceeding a slope of one unit vertical in 12 units horizontal (8.33-percent slope).

311.8.3.1 Height. Handrail height, measured above the finished surface of the ramp slope, shall be not less than 34 inches (864 mm) and not more than 38 inches (965 mm).

311.8.3.2 Grip size. Handrails on ramps shall comply with Section 311.7.8.5.

311.8.3.3 Continuity. Handrails where required on ramps shall be continuous for the full length of ramp. Handrail ends shall return or shall terminate in newel posts or safety terminals. Handrails adjacent to a wall shall have a space of not less than 1¹/₂ -inches (38 mm) between the wall and the handrails.

SECTION 312
GUARDS AND WINDOW FALL PROTECTION

312.1 Guards. Guards shall be provided in accordance with Sections 312.1.1 through 312.1.4.

312.1.1 Where required. Guards shall be provided for those portions of open-sided walking surfaces, including stairs, ramps and landings, that are located more than 30 inches (762 mm) measured vertically to the floor or grade below at any point within 36 inches (914 mm) horizontally to the edge of the open side. Insect screening shall not be considered as a guard.

Exception: Guards are not required where a protective bar is installed 34 inches to 38 inches (864 mm to 965 mm) above the porch or deck on the interior side of the screening. The protective bar shall be capable of resisting a horizontal load of 50 pounds per lineal foot (730 N/m) without contacting the screen and be a minimum of 1½ inches (38 mm) in height.

312.1.2 Height. Required guards at open-sided walking surfaces, including stairs, porches, balconies or landings, shall be not less than 36 inches (914 mm) in height as measured vertically above the adjacent walking surface or the line connecting the nosings.

Exceptions:

1. Guards on the open sides of stairs shall have a height of not less than 34 inches (864 mm) measured vertically from a line connecting the nosings.
2. Where the top of the guard serves as a handrail on the open sides of stairs, the top of the guard shall be not less than 34 inches (864 mm) and not more than 38 inches (965 mm) as measured vertically from a line connecting the nosings.

312.1.3 Opening limitations. Required guards shall not have openings from the walking surface to the required guard height that allow passage of a sphere 4 inches (102 mm) in diameter.

Exceptions:

1. The triangular openings at the open side of stair, formed by the riser, tread and bottom rail of a guard, shall not allow passage of a sphere 6 inches (153 mm) in diameter.
2. Guards on the open side of stairs shall not have openings that allow passage of a sphere 4³/₈ -inches (111 mm) in diameter.

312.1.4 Exterior plastic composite guards. Plastic composite exterior guards

shall comply with the requirements of Section 317.4.

312.2 Window fall protection. *When provided, window fall protection shall be in accordance with Sections 312.2.1 and 312.2.2.*

312.2.1 Window fall prevention devices. *Window fall prevention devices and window guards, where provided, shall comply with the requirements of ASTM F 2090.*

312.2.2 Window opening limiting devices. *Where provided, window opening limiting devices shall comply with the provisions of this section.*

312.2.2.1 General requirements. *Window opening limiting devices shall be self-acting and shall be positioned to prohibit the free passage of a 4-in. (102-mm) diameter rigid sphere through the window opening when the window opening limiting device is installed in accordance with the manufacturer's instructions.*

312.2.2.2 Operation for emergency escape. *Window opening limiting devices shall be designed with release mechanisms to allow for emergency escape through the window opening without the need for keys, tools or special knowledge. Window opening limiting devices shall comply with all of the following:*

- 1. Release of the window opening-limiting device shall require no more than 15 pounds (66 N) of force.**
- 2. The window opening limiting device release mechanism shall operate properly in all types of weather.**
- 3. Window opening limiting devices shall have their release mechanisms clearly identified for proper use in an emergency.**
- 4. The window opening limiting device shall not reduce the minimum net clear opening area of the window unit below what is required by Section 310.1.1 of the code.**

SECTION 313 **AUTOMATIC FIRE SPRINKLER SYSTEMS**

313.1 Dwelling unit automatic fire sprinkler systems. *An automatic residential fire sprinkler system is not required to be installed in buildings with four or more dwelling units or other Group R occupancies permitted to use this code.*

313.1.1 Design and installation for non-required systems. *When a non-*

required automatic residential fire sprinkler system is intended to be installed within a building with four or more dwelling units or a dwelling in another R-3 occupancy using this code, the system shall be designed and installed in accordance with Section 2904, NFPA 13, NFPA 13R or NFPA 13D as referenced in Chapter 44 of this code.

313.2 One-, two- and three-family dwellings automatic fire systems. An automatic residential fire sprinkler system is not required to be installed in one-, two-, or three-family dwellings.

313.2.1 Design and installation for non-required systems. When an automatic residential fire sprinkler system is intended to be installed, it shall be designed and installed in accordance with Section 2904, NFPA 13, NFPA 13R or NFPA 13D as referenced in Chapter 44 of this code.

313.3 Design and installation of non-required fire sprinkler systems. Any full or partial fire sprinkler system not required by this code shall be permitted to be installed for partial or complete protection provided that such system meets the requirements of this code to the extent of the intended installation.

SECTION 314 **SMOKE ALARMS**

314.1 General. Smoke alarms shall comply with the household fire warning equipment provisions of NFPA 72 and Section 314.

314.1.1 Listings. Smoke alarms shall be listed and labeled in accordance with UL 217. Combination smoke and carbon monoxide alarms shall be listed and labeled in accordance with UL 217 and UL 2034.

314.1.2 Technologies. On each level within each dwelling unit smoke alarms utilizing photoelectric and ionization technologies shall be installed. Separate or dual-sensing smoke alarms may be used. A smoke alarm located in accordance with section 314.3(2) shall include photoelectric technology.

Exception: A system meeting the requirements of Section 314.7 is not required to include both technologies.

314.2 Where required. Smoke alarms shall be provided in accordance with this section.

314.2.1 New construction. Smoke alarms shall be provided in dwelling units

in the locations described in Section 314.3.

314.2.2 Alterations, repairs and additions. Where alterations, repairs or additions requiring an approval occur, smoke alarms shall be installed, as required for new construction, as follows:

1. When alterations or repairs are made to spaces described in items 1 and 2 of Section 314.3, smoke alarms shall be provided in those areas.
2. When one or more sleeping rooms are added to or created in existing dwelling units, the new sleeping rooms and the immediate vicinity outside each sleeping room shall be equipped with smoke alarms.

Exceptions:

1. Work involving the exterior surfaces of dwellings, such as the replacement of roofing or siding, the addition or replacement of windows or doors, or the addition of a porch or deck.
2. Installation, alteration or repairs of plumbing or mechanical systems.

314.3 Location. Smoke alarms shall be installed in the following locations:

1. In each sleeping room.
2. Outside each separate sleeping area in the immediate vicinity of the *sleeping rooms*.
3. On each additional story of the dwelling, including basements and habitable attics and not including crawl spaces and uninhabitable attics. In dwellings or dwelling units with split levels and without an intervening door between the adjacent levels, a smoke alarm installed on the upper level shall suffice for the adjacent lower level provided that the lower level is less than one full story below the upper level.
4. Smoke alarms shall be installed not less than 3 feet (914 mm) horizontally from the door or opening of a bathroom that contains a bathtub or shower unless this would prevent placement of a smoke alarm required by this section.

314.3.1 Installation near cooking appliances. Smoke alarms shall not be installed in the following locations unless this would prevent placement of a smoke alarm in a location required by Section 314.3.

1. Ionization smoke alarms shall not be installed less than 20 feet (6096 mm) horizontally from a permanently installed cooking appliance.
2. Ionization smoke alarms with an alarm-silencing switch shall not be installed less than 10 feet (3048 mm) horizontally from a permanently installed cooking appliance.
3. Photoelectric smoke alarms shall not be installed less than 6 feet

(1828 mm) horizontally from a permanently installed cooking appliance.

314.4 Interconnection. Where more than one smoke alarm is required to be installed within an individual dwelling unit in accordance with Section 314.3, the alarm devices shall be interconnected in such a manner that the actuation of one alarm will activate all of the alarms in the individual dwelling unit. Physical interconnection of smoke alarms shall not be required where listed and labeled wireless alarms are installed and all alarms sound upon activation of one alarm.

Exception: Interconnection of smoke alarms in existing areas shall not be required where the alterations or repairs do not result in the removal of interior wall or ceiling finishes exposing the structure, unless there is an attic, crawl space or basement available which could provide access for interconnection without the removal of interior finishes.

314.5 Combination alarms. Combination smoke and carbon monoxide alarms shall be permitted to be used in lieu of smoke alarms.

314.6 Power source. Smoke alarms shall receive their primary power from the building wiring where such wiring is served from a commercial source and, where primary power is interrupted, shall receive power from a battery. Wiring shall be permanent and without a disconnecting switch other than those required for overcurrent protection.

Exceptions:

1. Smoke alarms shall be permitted to be battery operated where installed in buildings without commercial power.
2. *Hard-wiring of smoke alarms in existing areas shall not be required where the alterations or repairs do not result in the removal of interior wall or ceiling finishes exposing the structure, unless there is an attic, crawl space or basement available which could provide access for hard wiring without the removal of interior finishes.*

314.7 Fire alarm systems. Fire alarm systems shall be permitted to be used in lieu of smoke alarms and shall comply with Sections 314.7.1 through 314.7.4.

314.7.1 General. Fire alarm systems shall comply with the provisions of this code and the household fire warning equipment provisions of NFPA 72. Smoke detectors shall be listed in accordance with UL 268.

314.7.2 Location. Smoke detectors shall be installed in the locations specified in Section 314.3.

314.7.3 Permanent fixture. Where a household fire alarm system is installed, it shall become a permanent fixture of the occupancy, owned by the homeowner.

Exception. Where separate smoke alarms are provided meeting all other requirements of this section, the fire alarm system is not required to be a permanent fixture of the occupancy or owned by the homeowner.

314.7.4 Combination detectors. Combination smoke and carbon monoxide detectors shall be permitted to be installed in fire alarm systems in lieu of smoke detectors, provided that they are listed in accordance with UL 268 and UL 2075.

SECTION 315 **CARBON MONOXIDE ALARMS**

315.1 General. Carbon monoxide alarms shall comply with Section 315.

315.1.1 Listings. Carbon monoxide alarms shall be listed and labeled in accordance with UL 2034 and shall be installed in accordance with the manufacturer's instructions. Combination carbon monoxide and smoke alarms shall be listed and labeled in accordance with UL 2034 and UL 217.

315.2 When required. Carbon monoxide alarms shall be provided in accordance with Sections 315.2.1 and 315.2.2.

315.2.1 New construction. For new construction, carbon monoxide alarms shall be provided in dwelling units where either or both of the following conditions exist.

1. The dwelling unit contains a fuel-fired appliance.
2. The dwelling unit has an attached garage

315.2.2 Alterations, repairs and additions. In existing dwelling units, having fuel-fired appliances or an attached garage, where an application for approval is required for work involving any of the following areas or systems within that dwelling unit, the individual dwelling unit shall be equipped with carbon monoxide alarms located as required for new dwellings:

1. The addition or creation of a new sleeping room
2. An alteration of a sleeping room
3. An alteration in the immediate vicinity outside of a sleeping room;
4. An addition of, or an alteration to, an attached garage;
5. An addition, alteration, repair or replacement of a fuel-fired appliance.

315.3 Location. Carbon monoxide alarms in dwelling units shall be installed outside of each separate sleeping area in the immediate vicinity of the bedrooms. Where a fuel-burning appliance is located within a bedroom or its attached bathroom, a carbon monoxide alarm shall be installed within the bedroom.

315.4 Combination alarms. Combination carbon monoxide and smoke alarms shall be permitted to be used in lieu of carbon monoxide alarms.

315.5 Interconnectivity. *Deleted*

315.6 Power source. *Deleted*

315.7 Carbon monoxide detection systems. Carbon monoxide detection systems shall be permitted to be used in lieu of carbon monoxide alarms and shall comply with Sections 315.7.1 through 315.7.4.

315.7.1 General. Household carbon monoxide detection systems shall comply with NFPA 720. Carbon monoxide detectors shall be listed *and labeled* in accordance with UL 2075.

315.7.2 Location. Carbon monoxide detectors shall be installed in the locations specified in Section 315.3. These locations supersede the locations specified in NFPA 720.

315.7.3 Permanent fixture. Where a household carbon monoxide detection system is installed, it shall become a permanent fixture of the occupancy and owned by the homeowner.

Exception. *Where separate carbon monoxide alarms are provided meeting all other requirements of this section, the carbon monoxide detection system is not required to be a permanent fixture of the occupancy or owned by the homeowner.*

315.7.4 Combination detectors. Combination carbon monoxide and smoke detectors installed in carbon monoxide detection systems in lieu of carbon monoxide detectors shall be listed *and labeled* in accordance with UL 2075 and UL 268.

SECTION 316 **FOAM PLASTIC**

316.1 General. The provisions of this section shall govern the materials, design, application, construction and installation of foam plastic materials.

316.2 Labeling and identification. Packages and containers of foam plastic insulation and foam plastic insulation components delivered to the job site shall bear the label of an approved agency showing the manufacturer's name, the product listing, product identification and information sufficient to determine that the end use will comply with the requirements.

316.3 Surface burning characteristics. Unless otherwise allowed in Section 316.5, foam plastic, or foam plastic cores used as a component in manufactured assemblies, used in building construction shall have a flame spread index of not more than 75 and shall have a smoke-developed index of not more than 450 when tested in the maximum thickness and density intended for use in accordance with ASTM E84 or UL 723. Loose-fill-type foam plastic insulation shall be tested as board stock for the flame spread index and smoke- developed index.

Exception: Foam plastic insulation more than 4 inches (102 mm) thick shall have a flame spread index of not more than 75 and a smoke-developed index of not more than 450 where tested at a thickness of not more than 4 inches (102 mm), provided that the end use is approved in accordance with Section 316.6 using the thickness and density intended for use.

316.4 Thermal barrier. Unless otherwise allowed in Section 316.5, foam plastic shall be separated from the interior of a building by an approved thermal barrier of not less than 1/2 -inch (12.7 mm) gypsum wallboard, 23/32 -inch (18.2 mm) wood structural panel or a material that is tested in accordance with and meets the acceptance criteria of both the Temperature Transmission Fire Test and the Integrity Fire Test of NFPA 275.

316.5 Specific requirements. The following requirements shall apply to these uses of foam plastic unless specifically approved in accordance with Section 316.6 or by other sections of the code or the requirements of Sections 316.2 through 316.4 have been met.

316.5.1 Masonry or concrete construction. The thermal barrier specified in Section 316.4 is not required in a masonry or concrete wall, floor or roof where the foam plastic insulation is separated from the interior of the building by not less than a 1-inch (25 mm) thickness of masonry or concrete.

316.5.2 Roofing. The thermal barrier specified in Section 316.4 is not required where the foam plastic in a roof assembly or under a roof covering is installed

in accordance with the code and the manufacturer's instructions and is separated from the interior of the building by tongue-and-groove wood planks or wood structural panel sheathing, in accordance with Section 803, that is not less than $1\frac{5}{32}$ inch (11.9 mm) thick bonded with exterior glue, identified as Exposure 1 and with edges supported by blocking or tongue-and-groove joints or an equivalent material. The smoke-developed index for roof applications shall not be limited.

316.5.3 Attics. The thermal barrier specified in Section 316.4 is not required where all of the following apply:

1. Attic access is required by Section 807.1.
2. The space is entered only for purposes of repairs or maintenance.
3. The foam plastic insulation has been tested in accordance with Section 316.6 or the foam plastic insulation is protected against ignition using one of the following ignition barrier materials:
 - 3.1. $1\frac{1}{2}$ -inch-thick (38 mm) mineral fiber insulation.
 - 3.2. $\frac{1}{4}$ -inch-thick (6.4 mm) wood structural panels.
 - 3.3. $\frac{3}{8}$ -inch (9.5 mm) particleboard
 - 3.4. $\frac{1}{4}$ -inch (6.4 mm) hardboard.
 - 3.5. $\frac{3}{8}$ -inch (9.5 mm) gypsum board.
 - 3.6. Corrosion-resistant steel having a base metal thickness of 0.016 inch (0.406 mm).
 - 3.7. $1\frac{1}{2}$ -inch-thick (38 mm) cellulose insulation.
 - 3.8. $\frac{1}{4}$ -inch (6.4 mm) fiber-cement panel, soffit or backer board.

The ignition barrier is not required where the foam plastic insulation has been tested in accordance with Section 316.6.

316.5.4 Crawl spaces. The thermal barrier specified in Section 316.4 is not required where all of the following apply:

1. Crawl space access is required by Section 408.4.
2. Entry is made only for purposes of repairs or maintenance.
3. The foam plastic insulation has been tested in accordance with Section 316.6 or the foam plastic insulation is protected against ignition using one of the following ignition barrier materials:
 - 3.1. $1\frac{1}{2}$ -inch-thick (38 mm) mineral fiber insulation.
 - 3.2. $\frac{1}{4}$ -inch-thick (6.4 mm) wood structural panels.
 - 3.3. $\frac{3}{8}$ -inch (9.5 mm) particleboard.
 - 3.4. $\frac{1}{4}$ -inch (6.4 mm) hardboard.
 - 3.5. $\frac{3}{8}$ -inch (9.5 mm) gypsum board.
 - 3.6. Corrosion-resistant steel having a base metal thickness of 0.016

- inch (0.406 mm).
- 3.7. 1/4 -inch (6.4 mm) fiber-cement panel, soffit or backer board.

316.5.5 Foam-filled exterior doors. Foam-filled exterior doors are exempt from the requirements of Sections 316.3 and 316.4.

316.5.6 Foam-filled garage doors. Foam-filled garage doors in attached or detached garages are exempt from the requirements of Sections 316.3 and 316.4.

316.5.7 Foam backer board. The thermal barrier specified in Section 316.4 is not required where siding backer board foam plastic insulation has a thickness of not more than 0.5 inch (12.7 mm) and a potential heat of not more than 2000 Btu per square foot (22 720 kJ/m²) when tested in accordance with NFPA 259 and it complies with one or more of the following:

1. The foam plastic insulation is separated from the interior of the building by not less than 2 inches (51 mm) of mineral fiber insulation.
2. The foam plastic insulation is installed over existing exterior wall finish in conjunction with re-siding.
3. The foam plastic insulation has been tested in accordance with Section 316.6.

316.5.8 Re-siding. The thermal barrier specified in Section 316.4 is not required where the foam plastic insulation is installed over existing exterior wall finish in conjunction with re-siding provided that the foam plastic has a thickness of not more than 0.5 inch (12.7 mm) and a potential heat of not more than 2000 Btu per square foot (22 720 kJ/m²) when tested in accordance with NFPA 259.

316.5.9 Interior trim. The thermal barrier specified in Section 316.4 is not required for exposed foam plastic interior trim, provided that all of the following are met:

1. The density is not less than 20 pounds per cubic foot (320 kg/m³).
2. The thickness of the trim is not more than 0.5 inch (12.7 mm) and the width is not more than 8 inches (204 mm).
3. The interior trim shall not constitute more than 10 percent of the aggregate wall and ceiling area of any room or space.
4. The flame spread index does not exceed 75 when tested in accordance with ASTM E84 or UL 723. The smoke-developed index is not limited.

316.5.10 Interior finish. Foam plastics used as interior finishes shall comply

with Section 316.6 and shall meet the flame spread index and smoke-developed index requirements of Sections 302.9.1 and 302.9.2.

316.5.11 Sill plates and headers. Foam plastic be spray applied to sill plates and headers or installed in the perimeter joist space without the thermal barrier specified in Section 316.4 shall comply with all of the following:

1. The thickness of the foam plastic shall be not more than 3¹/₄ inches (83mm).
2. The density of the foam plastic shall be in the range of 0.5 to 2.0 pounds per cubic foot (8 to 32 kg/m³).
3. The foam plastic shall have a flame spread index of 25 or less and an accompanying smoke-developed index of 450 or less when tested in accordance with ASTM E84 or UL 723.

316.5.12 Sheathing. Foam plastic insulation used as sheathing shall comply with Section 316.3 and Section 316.4. Where the foam plastic sheathing is exposed to the attic space at a gable or kneewall, the provisions of Section 316.5.3 shall apply. Where foam plastic insulation is used as exterior wall sheathing on framed wall assemblies, it shall comply with Section 316.8.

316.5.13 Floors. The thermal barrier specified in Section 316.4 is not required to be installed on the walking surface of a structural floor system that contains foam plastic insulation where the foam plastic is covered by not more than a nominal 1/2 -inch-thick (12.7 mm) wood structural panel or equivalent. The thermal barrier specified in Section 316.4 is required on the underside of the structural floor system that contains foam plastic insulation where the underside of the structural floor system is exposed to the interior of the building.

316.6 Specific approval. Foam plastic not meeting the requirements of Sections 316.3 through 316.5 shall be specifically approved on the basis of one of the following approved tests: NFPA 286 with the acceptance criteria of Section 302.9.4, FM 4880, UL 1040 or UL 1715, or fire tests related to actual end-use configurations. Approval shall be based on the actual end-use configuration and shall be performed on the finished foam plastic assembly in the maximum thickness intended for use. Assemblies tested shall include seams, joints and other typical details used in the installation of the assembly and shall be tested in the manner intended for use.

316.7 Termite damage. The use of foam plastics in areas of “very heavy” termite infestation probability shall be in accordance with Section 318.4.

316.8 Wind resistance. Foam plastic insulation complying with ASTM C578 and ASTM C1289 and used as exterior wall sheathing on framed wall assemblies shall comply with SBCA FS 100 for wind pressure resistance unless installed directly over a sheathing material that is separately capable of resisting the wind load or otherwise exempted from the scope of SBCA FS 100.

SECTION 317
PROTECTION OF WOOD AND WOOD-BASED PRODUCTS
AGAINST DECAY

317.1 Location required. Protection of wood and wood-based products from decay shall be provided in the following locations by the use of naturally durable wood or wood that is preservative-treated in accordance with AWPA U1.

1. Wood joists or the bottom of a wood structural floor where closer than 18 inches (457 mm) or wood girders where closer than 12 inches (305 mm) to the exposed ground in crawl spaces or unexcavated area located within the periphery of the building foundation.
2. Wood framing members that rest on concrete or masonry exterior foundation walls and are less than 8 inches (203 mm) from the exposed ground.
3. Sills and sleepers on a concrete or masonry slab that is in direct contact with the ground unless separated from such slab by an impervious moisture barrier.
4. The ends of wood girders entering exterior masonry or concrete walls having clearances of less than 1/2 inch (12.7 mm) on tops, sides and ends.
5. Wood siding, sheathing and wall framing on the exterior of a building having a clearance of less than 6 inches (152 mm) from the ground or less than 2 inches (51 mm) measured vertically from concrete steps, porch slabs, patio slabs and similar horizontal surfaces exposed to the weather.
6. Wood structural members supporting moisture-permeable floors or roofs that are exposed to the weather, such as concrete or masonry slabs, unless separated from such floors or roofs by an impervious moisture barrier.
7. Wood furring strips or other wood framing members attached directly to the interior of exterior masonry walls or concrete walls below grade except where an approved vapor retarder is applied between the wall and the furring strips or framing members.

317.1.1 Field treatment. *Deleted*

317.1.2 Ground contact. All wood in contact with the ground, embedded in

concrete in direct contact with the ground or embedded in concrete exposed to the weather that supports permanent structures intended for human occupancy shall be approved pressure-preservative-treated wood suitable for ground contact use, except that untreated wood used entirely below groundwater level or continuously submerged in fresh water shall not be required to be pressure-preservative treated.

317.1.3 Geographical areas. In geographical areas where experience has demonstrated a specific need, approved naturally durable or pressure-preservative-treated wood shall be used for those portions of wood members that form the structural supports of buildings, balconies, porches or similar permanent building appurtenances where those members are exposed to the weather without adequate protection from a roof, eave, overhang or other covering that would prevent moisture or water accumulation on the surface or at joints between members. Depending on local experience, such members typically include:

1. Horizontal members such as girders, joists and decking.
2. Vertical members such as posts, poles and columns.
3. Both horizontal and vertical members.

317.1.4 Wood columns. Wood columns shall be approved wood of natural decay resistance or approved pressure-preservative-treated wood.

Exceptions:

1. Columns exposed to the weather or in basements where supported by concrete piers or metal pedestals projecting 1 inch (25 mm) above a concrete floor or 6 inches (152 mm) above exposed earth and the earth is covered by an approved impervious moisture barrier.
2. Columns in enclosed crawl spaces or unexcavated areas located within the periphery of the building where supported by a concrete pier or metal pedestal at a height more than 8 inches (203 mm) from exposed earth and the earth is covered by an impervious moisture barrier.
3. Deck posts supported by concrete piers or metal pedestals projecting not less than 1 inch (25 mm) above a concrete floor or 6 inches (152 mm) above exposed earth.

317.1.5 Exposed glued-laminated timbers. The portions of glued-laminated timbers that form the structural supports of a building or other structure and are exposed to weather and not properly protected by a roof, eave or similar covering shall be pressure treated with preservative, or be manufactured from naturally durable or preservative-treated wood.

317.2 Quality mark. Lumber and plywood required to be pressure-preservative treated in accordance with Section 318.1 shall bear the quality mark of an approved inspection agency that maintains continuing supervision, testing and inspection over the quality of the product and that has been approved by an accreditation body that complies with the requirements of the American Lumber Standard Committee treated wood program.

317.2.1 Required information. The required quality mark on each piece of pressure-preservative-treated lumber or plywood shall contain the following information:

1. Identification of the treating plant.
2. Type of preservative.
3. The minimum preservative retention.
4. End use for which the product was treated.
5. Standard to which the product was treated.
6. Identity of the approved inspection agency.
7. The designation "Dry," if applicable.

Exception: Quality marks on lumber less than 1 inch (25 mm) nominal thickness, or lumber less than nominal 1 inch by 5 inches (25 mm by 127 mm) or 2 inches by 4 inches (51 mm by 102 mm) or lumber 36 inches (914 mm) or less in length shall be applied by stamping the faces of exterior pieces or by end labeling not less than 25 percent of the pieces of a bundled unit.

317.3 Fasteners and connectors in contact with preservative-treated and fire-retardant-treated wood. Fasteners, including nuts and washers, and connectors in contact with preservative-treated wood and fire-retardant-treated wood shall be in accordance with this section. The coating weights for zinc-coated fasteners shall be in accordance with ASTM A153. Stainless steel driven fasteners shall be in accordance with the material requirements of ASTM F1667.

317.3.1 Fasteners for preservative-treated wood. Fasteners, including nuts and washers, for preservative-treated wood shall be of hot-dipped, zinc-coated galvanized steel, stainless steel, silicon bronze or copper. Staples shall be of stainless steel. Coating types and weights for connectors in contact with preservative-treated wood shall be in accordance with the connector manufacturer's recommendations. In the absence of manufacturer's recommendations, not less than ASTM A653 type G185 zinc-coated galvanized steel, or equivalent, shall be used.

Exceptions:

1. 1/2 -inch-diameter (12.7 mm) or greater steel bolts.
2. Fasteners other than nails, staples and timber rivets shall be permitted to be of mechanically deposited zinc-coated steel with coating weights in accordance with ASTM B695, Class 55 minimum.
3. Plain carbon steel fasteners in SBX/DOT and zinc borate preservative-treated wood in an interior, dry environment shall be permitted.

317.3.2 Fastenings for wood foundations. Fastenings, including nuts and washers, for wood foundations shall be as required in AWC PWF.

317.3.3 Fasteners for fire-retardant-treated wood used in exterior applications or wet or damp locations. Fasteners, including nuts and washers, for fire-retardant-treated wood used in exterior applications or wet or damp locations shall be of hot-dipped, zinc-coated galvanized steel, stainless steel, silicon bronze or copper. Fasteners other than nails, staples and timber rivets shall be permitted to be of mechanically deposited zinc-coated steel with coating weights in accordance with ASTM B695, Class 55 minimum.

317.3.4 Fasteners for fire-retardant-treated wood used in interior applications. Fasteners, including nuts and washers, for fire-retardant-treated wood used in interior locations shall be in accordance with the manufacturer's recommendations. In the absence of the manufacturer's recommendations, Section 317.3.3 shall apply.

317.4 Plastic composites. Plastic composite exterior deck boards, stair treads, guards and handrails containing wood, cellulosic or other biodegradable materials shall comply with the requirements of Section 507.2.2.

SECTION 318 **PROTECTION AGAINST SUBTERRANEAN TERMITES**

318.1 Subterranean termite control methods. In areas subject to damage from termites as indicated by Table 301.2(1), protection shall be by one, or a combination, of the following methods:

1. Chemical termiticide treatment in accordance with Section 318.2.
2. Termite-baiting system installed and maintained in accordance with the label.
3. Pressure-preservative-treated wood in accordance with the provisions of Section 317.1.
4. Naturally durable termite-resistant wood.
5. Physical barriers in accordance with Section 318.3 and used in locations as

specified in Section 317.1.

6. Cold-formed steel framing in accordance with Sections 505.2.1 and 603.2.1.

318.1.1 Quality mark. Lumber and plywood required to be pressure-preservative treated in accordance with Section 318.1 shall bear the quality mark of an approved inspection agency that maintains continuing supervision, testing and inspection over the quality of the product and that has been approved by an accreditation body that complies with the requirements of the American Lumber Standard Committee treated wood program.

318.1.2 Field treatment. *Deleted*

318.2 Chemical termiticide treatment. Chemical termiticide treatment shall include soil treatment or field-applied wood treatment. The concentration, rate of application and method of treatment of the chemical termiticide shall be in strict accordance with the termiticide label.

318.3 Barriers. Approved physical barriers, such as metal or plastic sheeting or collars specifically designed for termite prevention, shall be installed in a manner to prevent termites from entering the structure. Shields placed on top of an exterior foundation wall shall be used only if in combination with another method of protection.

318.4 Foam plastic protection. In areas where the probability of termite infestation is “very heavy” as indicated in Figure 301.2(7), extruded and expanded polystyrene, polyisocyanurate and other foam plastics shall not be installed on the exterior face or under interior or exterior foundation walls or slab foundations located below grade. The clearance between foam plastics installed above grade and exposed earth shall be not less than 6 inches (152 mm).

Exceptions:

1. Buildings where the structural members of walls, floors, ceilings and roofs are entirely of noncombustible materials or pressure-preservative-treated wood.
2. Where in addition to the requirements of Section 318.1, an approved method of protecting the foam plastic and structure from subterranean termite damage is used.
3. On the interior side of basement walls.

SECTION 319
SITE ADDRESS

319.1 Address identification. *Buildings shall have approved address numbers, building numbers or approved building identification placed in a position that is plainly legible and visible from the street or road fronting the property. Where required by the fire code official, address identification shall be provided in additional approved locations to facilitate emergency response. Where access is by means of a private road and the building address cannot be viewed from the public way, a monument, pole or other sign or means shall be used to identify the structure. Address identification shall be maintained.*

SECTION 320 **ACCESSIBILITY**

320.1 Scope. *Where there are four or more dwelling units or sleeping units in a single structure, and the design qualifies for this code to apply, the provisions of section 320 shall apply.*

In structures with 1, 2 or 3 dwelling units, the accessibility provisions of this code are not required but when non-required accessibility components are intended to be installed inside the dwellings, they shall comply with the provisions for Type A, Type B, Type C (Visitable), or Accessible units in ICC/ANSI A117.1 listed in Chapter 44 to the extent of the installation.

320.1.1 Guestrooms. *A dwelling with guestrooms for primarily transient occupants shall comply with the provisions of Chapter 11 of the Ohio building code for Group R-3. For the purpose of applying the requirements of Chapter 11 of the Ohio building code, guestrooms shall be considered to be sleeping units.*

Exception: *Owner-occupied lodging houses with five or fewer guestrooms constructed in accordance with the Residential Code of Ohio are not required to be accessible.*

320.2 Applicability. *Where there are four or more dwelling units or sleeping units intended to be occupied as residences in a single structure, every dwelling unit shall be a Type B unit designed and constructed for accessibility in accordance with section 320 and the provisions for Type B units in Chapter 10 of the ICC/ANSI A117.1 listed in Chapter 44.*

Exception: *The number of Type B units is permitted to be reduced in accordance with Section 320.4.*

When this code applies to structures of four or more dwellings and Type B units are required, the common and public use areas serving the Type B dwellings and

the accessible route connecting the common and public use areas to the Type B units shall comply with ICC/ANSI A117.1 listed in Chapter 44.

320.3 Accessible route. At least one accessible route shall connect accessible building or facility entrances with the primary entrance of each Type B unit within the building or facility and with those exterior and interior spaces and facilities that serve the Type B units.

Exception:

If due to circumstances outside the control of the owner, either the slope of the finished ground level between accessible facilities and buildings exceeds one unit vertical in 12 units horizontal (1:12), or where physical barriers or legal restrictions prevent the installation of an accessible route, a vehicular route with parking that complies with ICC/ANSI A117.1 listed in Chapter 44 at each public or common use facility or building is permitted in place of the accessible route.

320.4 General exceptions. The required number of Type B units is permitted to be reduced in accordance with Sections 320.4.1 through 320.4.5.

320.4.1 Structures without elevator service. Where no elevator service is provided in a structure, only the dwelling units that are located on stories indicated in Sections 320.4.1.1 and 320.4.1.2 are required to be Type B units, respectively.

320.4.1.1 One story with Type B units required. At least one story containing dwelling units or sleeping units intended to be occupied as a residence shall be provided with an accessible entrance from the exterior of the structure and all units intended to be occupied as a residence on that story shall be Type B units.

320.4.1.2 Additional stories with Type B units. On all other stories that have a building entrance in proximity to arrival points intended to serve units on that story, as indicated in Items 1 and 2, all dwelling units intended to be occupied as a residence served by that entrance on that story shall be Type B units.

1. Where the slopes of the undisturbed site measured between the planned entrance and all vehicular or pedestrian arrival points within 50 feet (15 240 mm) of the planned entrance are 10 percent or less, and
2. Where the slopes of the planned finished grade measured between the entrance and all vehicular or pedestrian arrival points within 50

feet (15 240 mm) of the planned entrance are 10 percent or less.

Where no such arrival points are within 50 feet (15 240 mm) of the entrance, the closest arrival point shall be used unless that arrival point serves the story required by Section 320.4.1.1.

320.4.2 Multistory units. A multistory dwelling which is not provided with elevator service is not required to be a Type B unit. Where a multistory unit is provided with external elevator service to only one floor, the floor provided with elevator service shall be the primary entry to the unit, shall comply with the requirements for a Type B unit and a toilet facility shall be provided on that floor.

For purposes of applying section 320, multistory units are dwellings with finished, habitable space on more than one level of the unit.

320.4.3 Elevator service to the lowest story with units. Where elevator service in the building provides an accessible route only to the lowest story containing dwelling or sleeping units intended to be occupied as a residence, only the units on that story which are intended to be occupied as a residence are required to be Type B units.

320.4.4 Site impracticality. On a site with multiple non-elevator buildings, the number of units required by Section 320.4.1 to be Type B units is permitted to be reduced to a percentage which is equal to the percentage of the entire site having grades, prior to development, which are less than 10 percent, provided that all of the following conditions are met:

1. Not less than 20 percent of the units required by Section 320.4.1 on the site are Type B units;
2. Units required by Section 320.4.1, where the slope between the building entrance serving the units on that story and a pedestrian or vehicular arrival point is no greater than 8.33 percent, are Type B units;
3. Units required by Section 320.4.1, where an elevated walkway is planned between a building entrance serving the units on that story and a pedestrian or vehicular arrival point and the slope between them is 10 percent or less are Type B units; and
4. Units served by an elevator in accordance with Section 320.4.3 are Type B units.

320.4.5 Design flood elevation. The required number of Type B units shall not apply to a site where the required elevation of the lowest floor or the lowest

horizontal structural building members of non-elevator buildings are at or above the design flood elevation resulting in:

1. A difference in elevation between the minimum required floor elevation at the primary entrances and vehicular and pedestrian arrival points within 50 feet (15 240 mm) exceeding 30 inches (762 mm), and
2. A slope exceeding 10 percent between the minimum required floor elevation at the primary entrances and vehicular and pedestrian arrival points within 50 feet (15.24 m).

Where no such arrival points are within 50 feet (15.24 m) of the primary entrances, the closest arrival points shall be used.

SECTION 321 **ELEVATORS AND PLATFORM LIFTS**

321.1 Elevators. Where provided, passenger elevators, limited-use and limited-application elevators or private residence elevators shall comply with ASME A17.1/CSA B44.

321.2 Platform lifts. Where provided, platform lifts shall comply with ASME A18.1.

321.3 Accessibility. Elevators or platform lifts that are part of an accessible route shall also comply with ICC A117.1.

SECTION 322 **FLOOD-RESISTANT CONSTRUCTION**

322.1 General. Except where approved by the Flood Plain Administrator having jurisdiction or by variance granted, buildings and structures constructed in whole or in part in flood hazard areas, including A or V Zones and Coastal A Zones, as established in Table 301.2(1), and substantial improvement and repair of substantial damage of buildings and structures in flood hazard areas, shall be designed and constructed in accordance with the provisions contained in this section. Buildings and structures that are located in more than one flood hazard area shall comply with the provisions associated with the most restrictive flood hazard area. Buildings and structures located in whole or in part in identified floodways shall be designed and constructed in accordance with ASCE 24.

322.1.1 Alternative provisions. As an alternative to the requirements in Section 322, ASCE 24 is permitted subject to the limitations of this code and the limitations therein.

322.1.2 Structural systems. Structural systems of buildings and structures shall be designed, connected and anchored to resist flotation, collapse or permanent lateral movement due to structural loads and stresses from flooding equal to the design flood elevation.

322.1.3 Flood-resistant construction. Buildings and structures erected in areas prone to flooding shall be constructed by methods and practices that minimize flood damage.

322.1.4 Establishing the design flood elevation. The design flood elevation shall be used to define flood hazard areas. At a minimum, the design flood elevation shall be the higher of the following:

1. The base flood elevation at the depth of peak elevation of flooding, including wave height, that has a 1-percent (100-year flood) or greater chance of being equaled or exceeded in any given year.
2. The elevation of the design flood associated with the area designated on a flood hazard map adopted by the community, or otherwise legally designated.

322.1.4.1 Determination of design flood elevations. If design flood elevations are not specified, the building official is authorized to require the applicant to comply with either of the following:

1. Obtain and reasonably use data available from a federal, state or other source.
2. Determine the design flood elevation in accordance with accepted hydrologic and hydraulic engineering practices used to define special flood hazard areas. Determinations shall be undertaken by a registered design professional who shall document that the technical methods used reflect currently accepted engineering practice. Studies, analyses and computations shall be submitted in sufficient detail to allow thorough review and approval.

322.1.4.2 Determination of impacts. In riverine flood hazard areas where design flood elevations are specified but floodways have not been designated, the applicant shall demonstrate that the effect of the proposed buildings and structures on design flood elevations, including fill, when combined with other existing and anticipated flood hazard area

encroachments, will not increase the design flood elevation more than 1 foot (305 mm) at any point within the jurisdiction.

322.1.5 Lowest floor. The lowest floor shall be the lowest floor of the lowest enclosed area, including basement, and excluding any unfinished flood-resistant enclosure that is useable solely for vehicle parking, building access or limited storage provided that such enclosure is not built so as to render the building or structure in violation of this section.

322.1.6 Protection of mechanical, plumbing and electrical systems. Electrical systems, equipment and components; heating, ventilating, air-conditioning; plumbing appliances and plumbing fixtures; duct systems; and other service equipment shall be located at or above the elevation required in Section 322.2 or 322.3. If replaced as part of a substantial improvement, electrical systems, equipment and components; heating, ventilating, air-conditioning and plumbing appliances and plumbing fixtures; duct systems; and other service equipment shall meet the requirements of this section. Systems, fixtures, and equipment and components shall not be mounted on or penetrate through walls intended to break away under flood loads.

Exception: Locating electrical systems, equipment and components; heating, ventilating, air-conditioning; plumbing appliances and plumbing fixtures; duct systems; and other service equipment is permitted below the elevation required in Section 322.2 or 322.3 provided that they are designed and installed to prevent water from entering or accumulating within the components and to resist hydrostatic and hydrodynamic loads and stresses, including the effects of buoyancy, during the occurrence of flooding to the design flood elevation in accordance with ASCE 24. Electrical wiring systems are permitted to be located below the required elevation provided that they conform to the provisions of the electrical part of this code for wet locations.

322.1.7 Protection of water supply and sanitary sewage systems. New and replacement water supply systems shall be designed to minimize or eliminate infiltration of flood waters into the systems in accordance with the plumbing provisions of this code. New and replacement sanitary sewage systems shall be designed to minimize or eliminate infiltration of floodwaters into systems and discharges from systems into floodwaters in accordance with the *plumbing code*.

322.1.8 Flood-resistant materials. Building materials and installation methods used for flooring and interior and exterior walls and wall coverings

below the elevation required in Section 322.2 or 322.3 shall be flood damage-resistant materials that conform to the provisions of FEMA TB-2.

322.1.9 Manufactured homes. Deleted

322.1.10 As-built elevation documentation. A registered design professional shall prepare and seal documentation of the elevations specified in Section 322.2 or 322.3.

322.2 Flood hazard areas (including A Zones). Areas that have been determined to be prone to flooding and that are not subject to high-velocity wave action shall be designated as flood hazard areas. Flood hazard areas that have been delineated as subject to wave heights between 1¹/₂ feet (457 mm) and 3 feet (914 mm) or otherwise designated by the jurisdiction shall be designated as Coastal A Zones and are subject to the requirements of Section 322.3. Buildings and structures constructed in whole or in part in flood hazard areas shall be designed and constructed in accordance with Sections 322.2.1 through 322.2.3.

322.2.1 Elevation requirements.

1. Buildings and structures in flood hazard areas, including flood hazard areas designated as Coastal A Zones, shall have the lowest floors elevated to or above the base flood elevation plus 1 foot (305 mm), or the design flood elevation, whichever is higher.
2. In areas of shallow flooding (AO Zones), buildings and structures shall have the lowest floor (including basement) elevated to a height above the highest adjacent grade of not less than the depth number specified in feet (mm) on the FIRM plus 1 foot (305 mm), or not less than 3 feet (915 mm) if a depth number is not specified.
3. Basement floors that are below grade on all sides shall be elevated to or above base flood elevation plus 1 foot (305 mm), or the design flood elevation, whichever is higher.

Exception: Enclosed areas below the design flood elevation, including basements with floors that are not below grade on all sides, shall meet the requirements of Section 322.2.2.

322.2.2 Enclosed area below design flood elevation. Enclosed areas, including crawl spaces, that are below the design flood elevation shall:

1. Be used solely for parking of vehicles, building access or storage.
2. Be provided with flood openings that meet the following criteria and are installed in accordance with Section 322.2.2.1:
 - 2.1. The total net area of nonengineered openings shall be not less than

1 square inch (645 mm²) for each square foot (0.093 m²) of enclosed area where the enclosed area is measured on the exterior of the enclosure walls, or the openings shall be designed as engineered openings and the construction documents shall include a statement by a registered design professional that the design of the openings will provide for equalization of hydrostatic flood forces on exterior walls by allowing for the automatic entry and exit of floodwaters as specified in Section 2.7.2.2 of ASCE 24.

- 2.2. Openings shall be not less than 3 inches (76 mm) in any direction in the plane of the wall.
- 2.3. The presence of louvers, blades, screens and faceplates or other covers and devices shall allow the automatic flow of floodwater into and out of the enclosed areas and shall be accounted for in the determination of the net open area.

322.2.2.1 Installation of openings. The walls of enclosed areas shall have openings installed such that:

1. There shall be not less than two openings on different sides of each enclosed area; if a building has more than one enclosed area below the design flood elevation, each area shall have openings.
2. The bottom of each opening shall be not more than 1 foot (305 mm) above the higher of the final interior grade or floor and the finished exterior grade immediately under each opening.
3. Openings shall be permitted to be installed in doors and windows; doors and windows without installed openings do not meet the requirements of this section.

322.2.3 Foundation design and construction. Foundation walls for buildings and structures erected in flood hazard areas shall meet the requirements of Chapter 4.

Exception: Unless designed in accordance with Section 404:

1. The unsupported height of 6-inch (152 mm) plain masonry walls shall be not more than 3 feet (914 mm).
2. The unsupported height of 8-inch (203 mm) plain masonry walls shall be not more than 4 feet (1219 mm).
3. The unsupported height of 8-inch (203 mm) reinforced masonry walls shall be not more than 8 feet (2438 mm).

For the purpose of this exception, unsupported height is the distance from the finished grade of the under-floor space to the top of the wall.

322.2.4 Tanks. Underground tanks shall be anchored to prevent flotation, collapse and lateral movement under conditions of the base flood. Above-ground tanks shall be installed at or above the elevation required in Section 322.2.1 or shall be anchored to prevent flotation, collapse and lateral movement under conditions of the base flood.

322.3 Coastal high-hazard areas (including V Zones and Coastal A Zones, where designated). Areas that have been determined to be subject to wave heights in excess of 3 feet (914 mm) or subject to high-velocity wave action or wave-induced erosion shall be designated as coastal high-hazard areas. Flood hazard areas that have been designated as subject to wave heights between 1½ feet (457 mm) and 3 feet (914 mm) or otherwise designated by the jurisdiction shall be designated as Coastal A Zones. Buildings and structures constructed in whole or in part in coastal high-hazard areas and Coastal A Zones, where designated, shall be designed and constructed in accordance with Sections 322.3.1 through 322.3.10.

322.3.1 Location and site preparation.

1. New buildings and buildings that are determined to be substantially improved pursuant to Section 113.4 shall be located landward of the reach of mean high tide.
2. For any alteration of sand dunes and *other coastal features*, the building official shall require submission of an engineering analysis that demonstrates that the proposed alteration will not increase the potential for flood damage.

322.3.2 Elevation requirements.

1. Buildings and structures erected within coastal high hazard areas and Coastal A Zones, shall be elevated so that the bottom of the lowest horizontal structural members supporting the lowest floor, with the exception of piling, pile caps, columns, grade beams and bracing, is elevated to or above the base flood elevation plus 1 foot (305 mm) or the design flood elevation, whichever is higher.
2. Basement floors that are below grade on all sides are prohibited.
3. The use of fill for structural support is prohibited.
4. Minor grading, and the placement of minor quantities of fill, shall be permitted for landscaping and for drainage purposes under and around buildings and for support of parking slabs, pool decks, patios and walkways.
5. Walls and partitions enclosing areas below the design flood elevation shall meet the requirements of Sections 322.3.5 and 322.3.6.

322.3.3 Foundations. Buildings and structures erected in coastal high-hazard areas and Coastal A Zones shall be supported on pilings or columns and shall be adequately anchored to such pilings or columns. The space below the elevated building shall be either free of obstruction or, if enclosed with walls, the walls shall meet the requirements of Section 322.3.5. Pilings shall have adequate soil penetrations to resist the combined wave and wind loads (lateral and uplift). Water-loading values used shall be those associated with the design flood. Wind-loading values shall be those required by this code. Pile embedment shall include consideration of decreased resistance capacity caused by scour of soil strata surrounding the piling. Pile systems design and installation shall be certified in accordance with Section 322.3.9. Spread footing, mat, raft or other foundations that support columns shall not be permitted where soil investigations that are required in accordance with Section 401.4 indicate that soil material under the spread footing, mat, raft or other foundation is subject to scour or erosion from wave-velocity flow conditions. If permitted, spread footing, mat, raft or other foundations that support columns shall be designed in accordance with ASCE 24.

Exception: In Coastal A Zones, stem wall foundations supporting a floor system above and backfilled with soil or gravel to the underside of the floor system shall be permitted provided that the foundations are designed to account for wave action, debris impact, erosion and local scour. Where soils are susceptible to erosion and local scour, stem wall foundations shall have deep footings to account for the loss of soil.

322.3.4 Concrete slabs. Concrete slabs used for parking, floors of enclosures, landings, decks, walkways, patios and similar uses that are located beneath structures, or slabs that are located such that if undermined or displaced during base flood conditions could cause structural damage to the building foundation, shall be designed and constructed in accordance with one of the following:

1. To be structurally independent of the foundation system of the structure, to not transfer flood loads to the main structure, and to be frangible and break away under flood conditions prior to base flood conditions. Slabs shall be a maximum of 4 inches (102 mm) thick, shall not have turned-down edges, shall not contain reinforcing, shall have isolation joints at pilings and columns, and shall have control or construction joints in both directions spaced not more than 4 feet (1219 mm) apart.
2. To be self-supporting, structural slabs capable of remaining intact and functional under base flood conditions, including erosion and local scour, and the main structure shall be capable of resisting any added flood loads and effects of local scour caused by the presence of the slabs.

322.3.5 Walls below design flood elevation. Walls and partitions are permitted below the elevated floor, provided that such walls and partitions are not part of the structural support of the building or structure and:

1. Electrical, mechanical and plumbing system components are not to be mounted on or penetrate through walls that are designed to break away under flood loads; and
2. Are constructed with insect screening or open lattice; or
3. Are designed to break away or collapse without causing collapse, displacement or other structural damage to the elevated portion of the building or supporting foundation system. Such walls, framing and connections shall have a resistance of not less than 10 (479 Pa) and not more than 20 pounds per square foot (958 Pa) as determined using allowable stress design; or
4. Where wind loading values of this code exceed 20 pounds per square foot (958 Pa), as determined using allowable stress design, the construction documents shall include documentation prepared and sealed by a registered design professional that:
 - 4.1. The walls and partitions below the design flood elevation have been designed to collapse from a water load less than that which would occur during the base flood.
 - 4.2. The elevated portion of the building and supporting foundation system have been designed to withstand the effects of wind and flood loads acting simultaneously on structural and nonstructural building components. Water-loading values used shall be those associated with the design flood. Wind-loading values shall be those required by this code.
5. Walls intended to break away under flood loads as specified in Item 3 or 4 have flood openings that meet the criteria in Section 322.2.2, Item 2.

322.3.6 Enclosed areas below design flood elevation. Enclosed areas below the design flood elevation shall be used solely for parking of vehicles, building access or storage.

322.3.6.1 Protection of building envelope. An exterior door that meets the requirements of Section 609 shall be installed at the top of stairs that provide access to the building and that are enclosed with walls designed to break away in accordance with Section 322.3.5.

322.3.7 Stairways and ramps. Stairways and ramps that are located below the lowest floor elevations specified in Section 322.3.2 shall comply with one or

more of the following:

1. Be designed and constructed with open or partially open risers and guards.
2. Stairways and ramps not part of the required means of egress shall be designed and constructed to break away during design flood conditions without causing damage to the building or structure, including foundation.
3. Be retractable, or able to be raised to or above the lowest floor elevation, provided that the ability to be retracted or raised prior to the onset of flooding is not contrary to the means of egress requirements of the code.
4. Be designed and constructed to resist flood loads and minimize transfer of flood loads to the building or structure, including foundation.

Areas below stairways and ramps shall not be enclosed with walls below the design flood elevation unless such walls are constructed in accordance with Section 322.3.5.

322.3.8 Decks and porches. Attached decks and porches shall meet the elevation requirements of Section 322.3.2 and shall either meet the foundation requirements of this section or shall be cantilevered from or knee braced to the building or structure. Self-supporting decks and porches that are below the elevation required in Section 322.3.2 shall not be enclosed by solid, rigid walls, including walls designed to break away. Self-supporting decks and porches shall be designed and constructed to remain in place during base flood conditions or shall be frangible and break away under base flood conditions.

322.3.9 Construction documents. The construction documents shall include documentation that is prepared and sealed by a registered design professional that the design and methods of construction to be used meet the applicable criteria of this section.

322.3.10 Tanks. Underground tanks shall be anchored to prevent flotation, collapse and lateral movement under conditions of the base flood. Above-ground tanks shall be installed at or above the elevation required in Section 322.3.2. Where elevated on platforms, the platforms shall be cantilevered from or knee braced to the building or shall be supported on foundations that conform to the requirements of Section 322.3.

SECTION 323 **STORM SHELTERS**

323.1 General. This section applies to storm shelters where constructed as separate detached buildings or where constructed as safe rooms within buildings for the purpose of providing refuge from storms that produce high winds, such as tornados and hurricanes. In addition to other applicable requirements in this code, storm shelters shall be constructed in accordance with ICC/NSSA-500.

SECTION 324 **SOLAR ENERGY SYSTEMS**

324.1 General. Solar energy systems shall comply with the provisions of this section.

324.2 Solar thermal systems. Solar thermal systems shall be designed and installed in accordance with Chapter 23.

324.3 Photovoltaic systems. Photovoltaic systems shall be designed and installed in accordance with Sections 324.3.1 through 324.7.1, NFPA 70, *the fire code* and the manufacturer's installation instructions.

324.3.1 Equipment listings. Photovoltaic panels and modules shall be listed and labeled in accordance with UL 1703. Inverters shall be listed and labeled in accordance with UL 1741. Systems connected to the utility grid shall use inverters listed for utility interaction.

324.4 Rooftop-mounted photovoltaic systems. Rooftop-mounted photovoltaic panel systems installed on or above the roof covering shall be designed and installed in accordance with this section.

324.4.1 Structural requirements. Rooftop-mounted photovoltaic panel systems shall be designed to structurally support the system and withstand applicable gravity loads in accordance with Chapter 3. The roof on which these systems are installed shall be designed and constructed to support the loads imposed by such systems in accordance with Chapter 8.

324.4.1.1 Roof load. Portions of roof structures not covered with photovoltaic panel systems shall be designed for dead loads and roof loads in accordance with Sections 301.4 and 301.6. Portions of roof structures covered with photovoltaic panel systems shall be designed for the following load cases:

1. Dead load (including photovoltaic panel weight) plus snow load in accordance with Table 301.2(1).

2. Dead load (excluding photovoltaic panel weight) plus roof live load or snow load, whichever is greater, in accordance with Section 301.6.

324.4.1.2 Wind load. Rooftop-mounted photovoltaic panel or module systems and their supports shall be designed and installed to resist the component and cladding loads specified in Table 301.2(2), adjusted for height and exposure in accordance with Table 301.2(3).

324.4.2 Fire classification. Rooftop-mounted photovoltaic panel systems shall have the same fire classification as the roof assembly required in Section 902.

324.4.3 Roof penetrations. Roof penetrations shall be flashed and sealed in accordance with Chapter 9.

324.5 Building-integrated photovoltaic systems. Building-integrated photovoltaic systems that serve as roof coverings shall be designed and installed in accordance with Section 905.

324.5.1 Photovoltaic shingles. Photovoltaic shingles shall comply with Section 905.16.

324.5.2 Fire classification. Building-integrated photovoltaic systems shall have a fire classification in accordance with Section 902.3.

324.6 Roof access and pathways. Roof access, pathways and setback requirements shall be provided in accordance with Sections 324.6.1 through 324.6.2.1. Access and minimum spacing shall be required to provide emergency access to the roof, to provide pathways to specific areas of the roof, provide for smoke ventilation opportunity areas, and to provide emergency egress from the roof.

Exceptions:

1. Detached, non-habitable structures, including but not limited to detached garages, parking shade structures, carports, solar trellises and similar structures, shall not be required to provide roof access.
2. Roof access, pathways and setbacks need not be provided where the code official has determined that rooftop operations will not be employed.
3. These requirements shall not apply to roofs with slopes of two units vertical in 12 units horizontal (17-percent slope) or less.

324.6.1 Pathways. Not fewer than two pathways, on separate roof planes from

lowest roof edge to ridge and not less than 36 inches (914 mm) wide, shall be provided on all buildings. Not fewer than one pathway shall be provided on the street or driveway side of the roof. For each roof plane with a photovoltaic array, a pathway not less than 36 inches wide (914 mm) shall be provided from the lowest roof edge to ridge on the same roof plane as the photovoltaic array, on an adjacent roof plane, or straddling the same and adjacent roof planes. Pathways shall be over areas capable of supporting fire fighters accessing the roof. Pathways shall be located in areas with minimal obstructions such as vent pipes, conduit, or mechanical equipment.

324.6.2 Setback at ridge. For photovoltaic arrays occupying not more than 33 percent of the plan view total roof area, not less than an 18-inch (457 mm) clear setback is required on both sides of a horizontal ridge. For photovoltaic arrays occupying more than 33 percent of the plan view total roof area, not less than a 36-inch (914 mm) clear setback is required on both sides of a horizontal ridge.

324.6.2.1 Alternative setback at ridge. Where an automatic sprinkler system is installed within the dwelling in accordance with NFPA 13D or Section 2904, setbacks at ridges shall comply with one of the following:

1. For photovoltaic arrays occupying not more than 66 percent of the plan view total roof area, not less than an 18-inch (457 mm) clear setback is required on both sides of a horizontal ridge.
2. For photovoltaic arrays occupying more than 66 percent of the plan view total roof area, not less than a 36-inch (914 mm) clear setback is required on both sides of a horizontal ridge.

324.6.2.2 Emergency escape and rescue opening. Panels and modules installed on dwellings shall not be placed on the portion of a roof that is below an emergency escape and rescue opening. A pathway not less than 36 inches (914 mm) wide shall be provided to the emergency escape and rescue opening.

324.7 Ground-mounted photovoltaic systems. Ground-mounted photovoltaic systems shall be designed and installed in accordance with Section 301.

324.7.1 Fire separation distances. Ground-mounted photovoltaic systems shall be subject to the fire separation distance requirements determined by the local jurisdiction.

SECTION 325 **MEZZANINES**

- Deleted

SECTION 326
SWIMMING POOLS, SPAS AND HOT TUBS

- Deleted

SECTION 327
STATIONARY STORAGE BATTERY SYSTEMS

327.1 General. Stationary storage battery system shall comply with the provisions of this section.

327.2 Equipment listings. Stationary storage battery systems shall be listed and labeled for residential use in accordance with UL 9540.

Exceptions:

1. Where approved, repurposed unlisted battery systems from electric vehicles are allowed to be installed outdoors or in detached sheds located not less than 5 feet (1524 mm) from exterior walls, property lines and public ways.
2. Battery systems that are an integral part of an electric vehicle are allowed provided that the installation complies with Section 625.48 of NFPA 70.
3. Battery systems less than 1 kWh (3.6 megajoules).

327.3 Installation. Stationary storage battery systems shall be installed in accordance with the manufacturer's instructions and their listing, if applicable, and shall not be installed within the habitable space of a dwelling unit.

327.4 Electrical installation. Stationary storage battery systems shall be installed in accordance with NFPA 70. Inverters shall be listed and labeled in accordance with UL 1741 or provided as part of the UL 9540 listing. Systems connected to the utility grid shall use inverters listed for utility interaction.

327.5 Ventilation. Indoor installations of stationary storage battery systems that include batteries that produce hydro- gen or other flammable gases during charging shall be provided with ventilation in accordance with Section 1307.4.

327.6 Protection from impact. Stationary storage battery systems installed in a location subject to vehicle damage shall be protected by approved barriers.

SECTION 328

POST FRAME ACCESSORY STRUCTURES

328.1 Post frame accessory structures. *The following requirements serve as minimum standards for post and frame structures within all of the following structural limitations:*

1. Residential accessory structures,
2. Single story,
3. Solid exterior structural sheathing or metal roof, and solid wall panels,
4. No attic storage,
5. Maximum building width of thirty six feet including the overhang,
6. Maximum wall height of sixteen feet,
7. Maximum mean roof height of twenty feet, and
8. Maximum post spacing of eight feet.

Post and frame structures and portions thereof outside the above structural limitations of this standard shall be accompanied by structural calculations as required by the residential building official or designed under the provisions of section 106.5 of the Residential Code of Ohio (RCO). Post and frame structures shall comply with the structural design requirements of section 301 of the RCO.

328.2 Definition. *Post frame accessory structures consist of primary members (wood posts, beams & single span roof trusses or ceiling joist and rafters) and secondary members (wood roof purlins, wall girts, bracing & sheathing) where all loads are transmitted from the sheathing and the secondary members to the primary members which transfer all combined loads to the soil through vertical posts bearing on footings embedded in the ground. See Figure 328.*

328.3 Footings and foundations. *Footings and foundations shall comply with applicable provisions of 401. Post frame structures shall have poured in-place concrete footings installed below all posts. The top of the footing shall be a minimum of 48 inches below finished grade and have footing diameters complying with Table 328.3.*

TABLE 328.3
POST FRAME PIER FOOTING DIAMETERS ^{1,2,3,4}

	<i>Building width (length of truss) including overhang (feet)</i>			
	<i>24</i>	<i>28</i>	<i>32</i>	<i>36</i>
<i>Diameter (inches)</i> <i>20# roof snow load</i>	<i>18</i>	<i>20</i>	<i>22</i>	<i>22</i>
<i>Diameter (inches)</i> <i>30# roof snow load</i>	<i>18</i>	<i>22</i>	<i>24</i>	<i>26</i>

- 1. Pier footing thickness shall be a minimum one-half of the diameter of the footing.*
- 2. Based upon 2000 PSF soil bearing capacity and truss loads of 20 or 30 PSF live or snow load*

top chord, 10 PSF dead load top chord, 5 PSF dead load on the bottom chord and no live load on the bottom chord

3. Fractional widths shall be rounded to the next higher pier footing diameter.
4. Table not to be used in Ohio case study areas.

328.4 Post and wall construction. Posts shall be three (3) ply unspliced, reinforced spliced or solid wood and shall not be less than 4 inch by 6 inch nominal size. Posts shall comply with the requirements of Section 317.

328.4.1 Uplift protection: Posts shall have uplift protection by one of the following methods:

1. Two 2x6x12 inch post uplift protection blocks attached to each side of the base of the post. The post uplift blocks shall be placed horizontally, attached per Table 328.7 and comply with Section 317;
2. 12 inch high, concrete collar poured on top of footing around the post, with 2-#5x9 inch rebar placed through the post at 3 inches and 9 inches from bottom of post in opposite directions. The rebar ends must be 1 1/2 inches from the soil. See Figure 328.1;

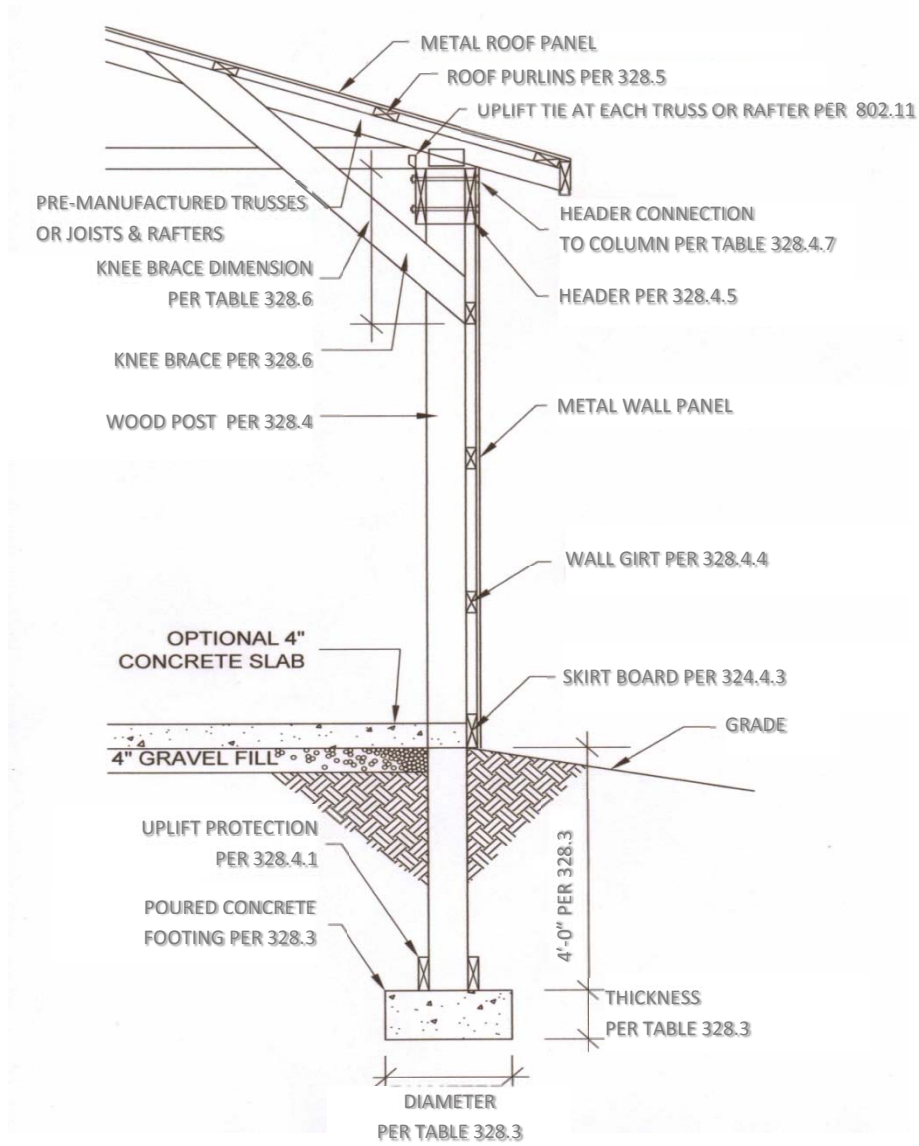

FIGURE 328
POST AND FRAME WALL SECTION.

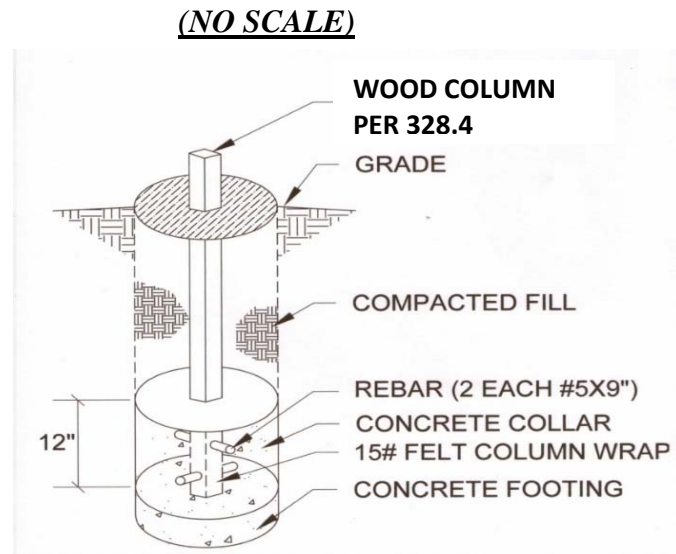

FIGURE 328.1
POST UPLIFT PROTECTION EXCEPTION
(NO SCALE)

328.4.2 Post Spacing. *The maximum spacing for posts shall be (eight) 8 feet on center.*

328.4.3 Skirt Boards. *Skirt boards shall be treated lumber meeting the requirements of Section 317 and attached per Table 328.7.*

328.4.4 Wall girts. *Wall girts shall be not less than 2 x 4 inches nominal and spaced not more than twenty-four (24) inches on center.*

328.4.5 Load bearing beams and headers: *Load bearing beams and headers shall comply with Table 502.5(1).*

Exceptions:

1. Bearing beams are not required if the trusses or ceiling joists and rafters bear directly on the posts.
2. Headers in the gable-end wall which do not support more than five square feet of wall area per lineal foot of header shall be sized per Table 328.4.5.

**TABLE 328.4.5
GABLE END HEADER SIZES.**

Opening Width (feet)	10	12	16
Header Size (inches)	2-2x8	2-2x10	2-2x12

328.4.6 Bracing. Wall bracing shall be provided to resist all racking and shearing forces and must comply with the applicable provisions of section 602.10 or by installing 2x6 diagonal cross braces in the bays between adjacent posts as described in this section. The diagonal cross braces shall be placed from the top header or girt to the next adjacent post at the skirt board. The cross bracing shall be placed or installed on all sides of the building and shall be spaced at a maximum of 25 feet on center and within 12 feet of the corners of the building and attached per Table 328.7. Any splices of the diagonal brace required due to excessive length, must lap over two consecutive wall girts.

328.4.7 Beams supporting trusses or rafters and ceiling joists attachment to column. Bearing beams supporting roof trusses or rafters and ceiling joists shall be connected to the posts by one of the following methods:

1. Bolts that are 1/2 inch diameter through-bolted to the side of the post;
2. Bolts that are 1/2 inch diameter, directly attached to a 3-ply post notch, enclosing the truss or rafter at the top of post; or
3. Other fasteners with minimum shear or withdraw values stated in Table 328.4.7

328.4.7.1 Number of fasteners. The minimum numbers of through bolts or other fasteners with minimum shears or withdraw values required per Table 328.4.7.

**TABLE 328.4.7
BEAM OR TRUSS CONNECTION AT POSTS
MINIMUM FASTENERS OR TOTAL SHEAR OR WITHDRAW VALUES ^{a,b,c}**

	Building Width (Length of Truss) including overhang (feet)			
	24	28	32	36
<u>Shear or withdraw (pounds)</u> <u>20 lb snow load</u>	3360	3920	4480	5040
<u>Number of Bolts,</u> <u>20 lb roof snow load</u>	2	2	2	3
<u>Shear or withdraw (pounds)</u> <u>30 lb roof snow load</u>	4320	5040	5760	6480
<u>Number of Bolts,</u> <u>30 lb roof snow load</u>	2	3	3	3

- a. Based upon truss loads of 20 or 30 PSF live or snow load top chord, 10 PSF dead load top chord, 5 PSF live load on the bottom chord and no live load on the bottom chord.
- b. Based upon post spacing at intervals not exceeding 8 feet.
- c. When beams are attached at each side of the column and fasteners do not extend through both beams such

as through-bolts, the required values are one-half the amount shown above for each beam.

328.5 Roof purlins. *Roof purlins shall be a minimum of 4x2 SPF#2 laid flat for spans up to 4 feet, and 4x2 SPF#2 laid on edge for spans up to 8 feet. Roof purlins shall be spaced not more than 24 inches on center.*

328.6 Knee bracing: *A 2x6 brace shall extend from the post to the top chord of the truss or rafter adjacent to the post at a 45 degree angle. The vertical distance down from the bottom chord of the truss or ceiling joist to the point where the brace attaches to the posts shall be in compliance with Table 328.6 as shown on Figure 328. Trusses or rafters must be spaced such that they align with the post intervals. Attachment of knee brace shall be per Table 328.7.*

TABLE 328.6
KNEE BRACE VERTICAL DISTANCE.

<u>Wall Height</u>	<u>Vertical Dimension</u>
<u>8'-0" and 9'-0"</u>	<u>1'-6"</u>
<u>10'-0" and 11'-0"</u>	<u>2'-0"</u>
<u>12'-0" and 13'-0"</u>	<u>3'-0"</u>
<u>14'-0" through 16'-0"</u>	<u>4'-0"</u>

328.7 Attachment details. *Structural fastener details for post and frame buildings shall comply with Table 328.7.*

TABLE 328.7
STRUCTURAL FASTENERS

<u>Fastener Schedule for Structural Members</u>		
<u>Description of Building Element</u>	<u>Number and Type of Fastener</u>	<u>Attachment type</u>
<u>Uplift blocking to post</u>	<u>5-16d Hot Dipped Galvanized</u>	<u>Each block</u>
<u>Skirt board to post</u>	<u>2-16d Hot Dipped Galvanized</u>	<u>Face nail</u>
<u>Wall girt to post</u>	<u>2-16d Hot Dipped Galvanized</u>	<u>Face nail</u>
<u>Diagonal cross bracing to post</u>	<u>2-16d Hot Dipped Galvanized</u>	<u>Face nail</u>
<u>Diagonal cross bracing to skirt board</u>	<u>2-10d Hot Dipped Galvanized</u>	<u>Face nail</u>
<u>Diagonal cross bracing to wall girts, beam, or header</u>	<u>2-10d</u>	<u>Face nail</u>
<u>Knee brace to post</u>	<u>3-16d Hot Dipped Galvanized</u>	<u>Face nail</u>
<u>Knee brace to top chord of truss or rafter</u>	<u>3-10d</u>	<u>Face nail</u>
<u>Knee brace to bottom chord of truss or ceiling joist</u>	<u>3-10d</u>	<u>Face nail</u>
<u>Roof purlin to truss or rafter with span of 2' or 4'</u>	<u>2-16d</u>	<u>Face nail</u>
<u>Roof purlin to truss or rafter with span of 8'</u>	<u>Mechanical fastener with uplift protection greater than 225 pounds.</u>	<u>Per manufacturer installation manual</u>

328.8 Roof trusses. *Engineered roof trusses, where used, shall be accompanied by*

drawings sealed by the registered design professional responsible for their preparation and shall be submitted to the residential building official for approval prior to the framing inspection. The truss design shall comply with Sections 802.10 and 802.11 and shall account for all loads imposed on the truss as a result of the prescriptive requirements of this section.

Replaces: 4101:8-3-01
Effective: 7/1/2019
Five Year Review (FYR) Dates: 07/01/2024

CERTIFIED ELECTRONICALLY

Certification

12/14/2018

Date

Promulgated Under: 119.03
Statutory Authority: 3781.10(A)(1)
Rule Amplifies: 3781.01, 4740.14, 3791.04, 3781.11, 3781.10, 3781.06
Prior Effective Dates: 05/27/2006, 01/01/2013, 07/01/2014, 01/01/2016